

Analytical Application Sets



4/2	Introduction
4/3	Set FLK "Continuous analysis of flue gas in the rotary kilns of cement factories"
4/13	Set GGA "Continuous monitoring of H ₂ -cooled generators"
4/18	Set CV "Determination of the quality of natural gas"
4/28	Set CEM "Continuous monitoring of emission components in flue gases"
4/28	Set CEM1
4/37	Gasmet CEMS "Continuous monitoring of flue gases"
4/50	Set ASM "Analyzer System Manager for monitoring, testing and administration of analyzers"
4/53	Set BGA "Standardized system for the analysis of biogas"

> 2 > ? @ > A 0 < ? @ > 4 0 6 8 ? > 4 4 5 @ 6 : 8 > 1 @ 0 1 0 9 B 5 A L :
 " 5 ; . / D 0 : A : + 7 (8 4 3) 2 0 6 - 0 1 - 4 8 (D 0 : A 4 > 1 . 0)
 s i m a t @ n t - r t . r u
 w w w . s i m a t . n t - r t . r u

Analytical Application Sets

Introduction

Overview

Standardization and the supply of complete packages are two trends that are currently on the up. This can be attributed to the fact that the same application is frequently required in different industrial sectors and overhead can be minimized in this case. Furthermore, customers often want to purchase turnkey systems to minimize the risk of any technical problems.

With its Analytical Application Set initiative, Siemens is making use of its wealth of experience to offer standardized packages that are designed with a single application in mind. Its range of applications can cover a variety of industrial sectors.

It is now possible to simply configure and order complete applications straight from the catalog, thereby sharply reducing the amount of time taken between the request and order.

All Analytical Application Sets are tested in advance and provide a high level of safety and reliability. The different versions cover a broad spectrum of potential applications and ensure that the sets can be configured for both minimum and maximum requirements.

The order structure makes it possible to choose from different versions and module components, as well as configure the system and order it directly.

4

По вопросам продаж и поддержки обращайтесь:

Архангельск (8182)63-90-72
Астана +7(7172)727-132
Астрахань (8512)99-46-04
Барнаул (3852)73-04-60
Белгород (4722)40-23-64
Брянск (4832)59-03-52
Владивосток (423)249-28-31
Волгоград (844)278-03-48
Вологда (8172)26-41-59
Воронеж (473)204-51-73
Екатеринбург (343)384-55-89
Иваново (4932)77-34-06
Ижевск (3412)26-03-58
Казань (843)206-01-48

Калининград (4012)72-03-81
Калуга (4842)92-23-67
Кемерово (3842)65-04-62
Киров (8332)68-02-04
Краснодар (861)203-40-90
Красноярск (391)204-63-61
Курск (4712)77-13-04
Липецк (4742)52-20-81
Магнитогорск (3519)55-03-13
Москва (495)268-04-70
Мурманск (8152)59-64-93
Набережные Челны (8552)20-53-41
Нижний Новгород (831)429-08-12
Новокузнецк (3843)20-46-81

Новосибирск (383)227-86-73
Омск (3812)21-46-40
Орел (4862)44-53-42
Оренбург (3532)37-68-04
Пенза (8412)22-31-16
Пермь (342)205-81-47
Ростов-на-Дону (863)308-18-15
Рязань (4912)46-61-64
Самара (846)206-03-16
Санкт-Петербург (812)309-46-40
Саратов (845)249-38-78
Севастополь (8692)22-31-93
Симферополь (3652)67-13-56
Смоленск (4812)29-41-54

Сочи (862)225-72-31
Ставрополь (8652)20-65-13
Сургут (3462)77-98-35
Тверь (4822)63-31-35
Томск (3822)98-41-53
Тула (4872)74-02-29
Тюмень (3452)66-21-18
Ульяновск (8422)24-23-59
Уфа (347)229-48-12
Хабаровск (4212)92-98-04
Челябинск (351)202-03-61
Череповец (8202)49-02-64
Ярославль (4852)69-52-93

Эл. почта: sai@nt-rt.ru || Сайт: <http://simat.nt-rt.ru>

Overview

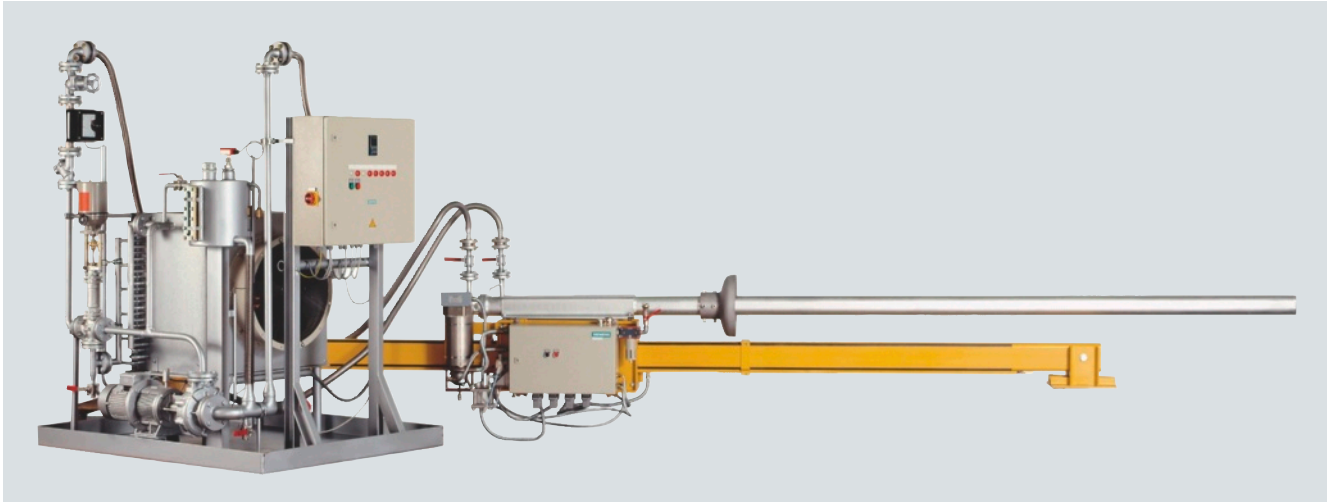

The Set FLK (liquid/air cooling) is a standardized set for gas sampling.

Application

Continuous analysis of flue gas in the rotary kilns of cement factories is essential for the quality of the generated clinker, the efficient use of fuel, and protection of the environment from toxic emissions:

- The analysis permits detailed assessment of the combustion processes, and is therefore a prerequisite for optimization of burner control, fuel requirements and product quality.
- Malfunctions can be detected at an early point in time, and prevented using appropriate countermeasures. At the same time, stable control of the kiln prevents the emission of toxic materials, thus supporting environmental protection.

In a rotary cement kiln, gas samples are usually taken from the intake area by means of a system such as the FLK gas sampling probe, and the concentrations of oxygen (O₂), carbon monoxide (CO) and nitrogen oxide (NO) measured continuously.

Oxygen (O₂) and carbon monoxide (CO)

During cement production, the largest share of production costs results from the amount of fuel used. On the one hand, complete combustion is important for reducing toxic materials in the exhaust gas, on the other hand an excess of oxygen is a waste of resources. Already an oxygen excess of 1 % means an increased energy consumption of 15 kcal per kg of generated clinker.

Measurement of the concentrations of O₂ and CO permits the furnace operator to optimize the combustion in the rotary kiln with respect to the quality of the generated clinker, reduction in toxic emissions, and reduced use of fuels.

Nitrogen oxide (NO)

The NO concentration in the rotary kiln largely depends on the flame temperature. A temperature held as constant as possible in the clinkering zone is of great significance for a high quality of the generated clinker. Variations in the clinkering zone temperature result in significant changes in the NO concentration.

The NO analysis is therefore an appropriate means for achieving stable and uniform operation of the kiln. Use of an NO₂ converter for measuring nitrogen oxides (NO and NO₂) is not recommended since with this analysis the variation is more important than the absolute value of the nitrogen oxide concentration.

Sulfur dioxide (SO₂)

Because of the increasing share of alternative fuels, some of which have very high sulfur concentrations, analysis of SO₂ in the rotary kiln is becoming increasingly important. High concentrations of SO₂ in the gas circuits result in increased corrosion and frequently to undesirable caking of material in the rotary kiln and in the cyclones of the heat exchanger. In addition, a fast rise in the SO₂ concentration is an early warning of a combustion fault.

The difficult environmental conditions in rotary kilns place high demands on the sampling systems. Problematical are the high gas temperature up to 1400 °C, the high dust concentration of up to 2000 g/m³ and the high concentrations of alkali, sulfate and chloride in the gas circuits. In addition, the gas sampling probe is subject to high mechanical stress resulting from falling material or the inflowing raw meal.

In particular, high concentrations of sulfur and alkali very frequently result in blockages in the gas paths, necessitating over-proportionally high maintenance of the gas sampling equipment.

The FLK gas sampling probe uses a heat transfer liquid with a boiling point of above 300 °C as the coolant. The temperature of the sampled flue gas is up to 200 °C, and is above its acid dew point. This reliably prevents condensation of the flue gas, which, together with the existing dust, can rapidly result in blockages.

Design

The FLK gas sampling system consists of the following components:

Liquid-cooled sampling probe

The probe is available with an immersion depth of between 1 500 and 3 500 mm. It is manufactured from stainless steel mat. no. 1.4571 and its oval shape gives it a high vertical flexion strength. The sampling point is at the tip of the probe on the side pointing away from the flow in order to suck in as little dust as possible from the gas.

The probe is suitable for process gas temperatures of up to 1 400 °C.



Liquid-cooled sampling probe

Electrically heated dust filter

The dust filter is used to purify the gas/dust mixture extracted from the process area, and is suitable for dust loads of up to 2 000 g/m³.

Electrical heating up to a temperature of approx. 200 °C prevents crustation or caking of the filter pipe.

Cleaning is carried out automatically at regular intervals, using compressed air at a pressure of approx. 8 bar. To avoid blockage of the filter pores, the compressed air must be free of oil and water residues. Oil residue in particular can lead to caking in the filter pores, which then cannot be removed using compressed air cleaning.

Depending on the dust load, the dust filter can be fitted with filter pipes with different pore sizes.



Electrically heated dust filter

Compressed air valve manifold

Together with the PLC, the valve manifold carries out the regular cleaning programs for purging the gas sampling system.

The purging frequency and duration can be adapted to the conditions of the respective plant using the operator panel of the control unit.

Purging can be initiated manually at any time using the integrated pushbutton. An integrated pressure switch detects imminent blockages in the gas paths as early as possible, and initiates immediate purging of the gas sampling system by sending a signal to the control unit.

A condensation trap is fitted on the valve manifold for preliminary separation of condensation and dust from the process gas.

The sample gas is cut off from the downstream gas preparation by means of a four-way solenoid valve with metal-free gas paths.

For purging purposes, compressed air that is free from dust, water and oil and has a pressure of approximately 8 000 hPa must be provided.

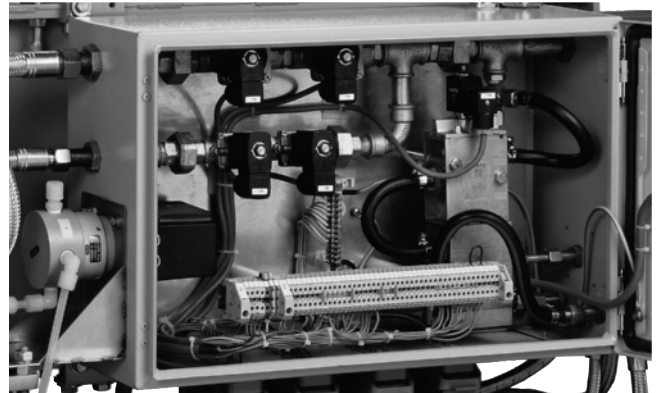

Compressed air valve manifold

Retraction unit with electrical and pneumatic drive

In the event of an incident, the retraction unit automatically removes the probe from the rotary kiln in order to protect it against thermal overload. Depending on the probe length, approx. 90 seconds are required up to complete retraction. An electrical geared motor is used as the drive.

Faults that result in immediate retraction of the probe are:

- Excessively high temperature in cooling circuit
- Coolant level below minimum
- Flow fault

Should the power supply fail, emergency retraction of the probe is carried out by a pneumatic motor provided the supply with compressed air is guaranteed. For maintenance purposes, the probe can be manually retracted at any time using a pushbutton.

The heavy-duty industrial design of the retraction unit guarantees reliable and practically maintenance-free operation.



Retraction unit with electrical and pneumatic drive

Heat exchange unit

The gas sampling probe is cooled by means of a depressurized air/liquid heat exchanger. Use of a synthetic heat transfer liquid with a boiling point above 300 °C permits temperatures of up to 200 °C in the cooling circuit, and therefore equivalent gas sampling temperatures.

To prevent condensation of the flue gas in the gas sampling equipment, gas sampling is only enabled if the temperature in the cooling circuit is at least 130 °C.

The temperature in the cooling circuit is kept as constant as possible by controlling the flow by means of a speed-controlled circulation pump. Depending on the temperature, the flow can be between 1 000 and 3 500 m³/h.



Heat exchange unit

Control and monitoring unit

The core of the FLK gas sampling equipment is the compact control and monitoring unit with Siemens SIMATIC S7-300 programmable logic controller.

In addition to the monitoring functions for safe operation of the probe, the control unit is also responsible for regular cleaning of the gas paths.

The operator can use an integrated operator panel to adjust all the parameters, such as the frequency and duration of probe purging, to suit the requirements of the respective plant. No programming knowledge is required to do this.



Control and monitoring unit

Mode of operation

Installation and commissioning

Installation of the FLK probe

A number of points must be observed to permit low-maintenance operation of the gas sampling equipment:

- Preferably installation at the side on the kiln intake chamber opposite the raw meal intake
- The probe must not pass through the material flow of the heat exchanger (danger of mechanical damage and baking of material on probe jacket)
- Take into account the possibility of falling material
- To avoid the sucking-in of incorrect air, the sampling point should be located approx. 30 cm behind the kiln seal
- The lateral distance from the kiln lining should not be less than 20 cm
- Depending on the design of the retraction unit, sufficient space must be provided behind the probe's mounting location

In case of doubt, please consult an expert.

Installation of the heat exchanger

The heat exchanger should be installed close to the probe, and at the same level if possible. The coolant lines should be kept as short as possible to avoid falsification of the coolant temperature in the probe. Excessive heat radiation on the coolant lines can lead to overheating of the probe in the extreme case since the coolant temperature is measured in the heat exchanger. If the heat exchanger has to be installed further away from the probe for space reasons, the coolant lines must be insulated against heat loss.

Strictly observe the information in the manual when connecting the coolant lines.

The heat exchanger has a thermal output of up to 65 kW. Sufficient ventilation for dissipation of the heat must be provided. During operation, the surfaces of the heat exchanger can reach a temperature of up to 250 °C. To protect against touching by mistake, customers must provide a protective grid around the heat exchanger.

Installation of the retraction unit

A space of approx. 6 000 mm is required behind the probe's mounting location for installation of the retraction unit. If the required space is not available, the retraction unit can be shortened depending on the probe length. For a probe with an immersion depth of 2 500 mm, the minimum length of the retraction unit is approx. 4 700 mm.

The dust filter and valve manifold supplied separately must be fitted to the side of the retraction unit during the mounting.

Installation of the control cabinet

The control cabinet should preferably be installed in a dust-proof room, usually the analyzer room.

Routing of sample gas line

Particularly with non-heated sample gas lines, a continuous downward gradient must be provided from the sampling point to the analyzer cabinet in order to avoid water pockets. Any resulting condensation must be able to flow off before the analyzer cabinet.

A heated sample gas line is absolutely essential when measuring SO₂ or if there is a danger of freezing.

In order to achieve T₉₀ times which are as low as possible, the nominal diameter of the sample gas line should be selected as small as possible.

Flow	for 1 m gas line upstream of gas analyzer	
	Nominal diameter 4 mm	Nominal diameter 6 mm
0.5 l/min	1.6 s	4.3 s
1.0 l/min	0.8 s	2.1 s
1.5 l/min	0.6 s	1.5 s
2.0 l/min	0.4 s	1.1 s

Delayed display depending on flow rate

Compressed air connection

A compressed air connection with a pressure of 6 000 to 8 000 hPa is required to purge the probe and for operation of the pneumatic motor. The compressed air must be free of oil, water and dust. Moisture in the compressed air results in premature blockage of the pores in the dust filter and increased maintenance effort.

Oil in the compressed air can result in caking of the filter pores which can no longer be removed, necessitating replacement of the sintered metal filter.

Electrical connections

The electrical connections must be made according to the directives of the local power supply company and the directives of the respective country.

A period of approx. 5 days should be calculated for mounting. Mounting is usually carried out by the customer.

Commissioning

Starting up of the complete equipment should always be carried out by trained Siemens personnel. Prior to startup, the installation must be checked for observation of the directives according to the manuals.

Starting up should be carried out with the kiln in operation in order to carry out the required settings and optimization.

A period of approx. 3 to 5 days should be calculated for starting up.

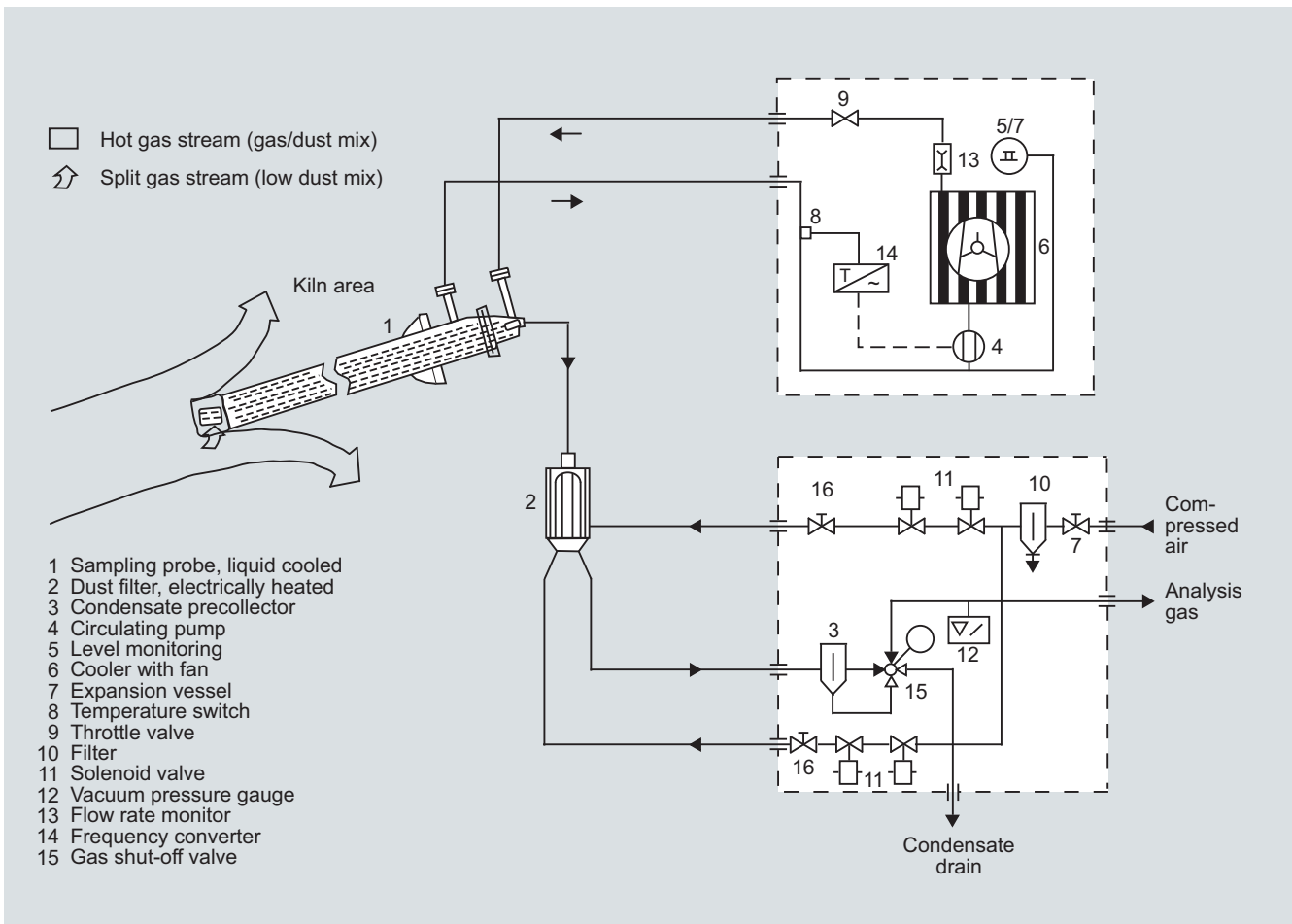

Mode of operation

Function

The process gas to be analyzed is sampled by the gas sampling probe, purified in the electrically heated dust filter, and then applied to the gas analyzer. Because the opening is positioned at the side, only a part of the gas flow which has a particularly low dust concentration is sampled.

To reduce the load on the gas cooler in the analyzer cabinet, a condensation trap is present on the valve manifold. During purging of the sampling equipment, the resulting condensation is discharged from the tank.

During operation in an environment up to 1 400 °C, the probe is cooled by a heat exchanger operating at atmospheric pressure. An electronic control valve provides short heating-up times following initial insertion of the probe, and controls the temperature of the coolant in the cooling circuit.

Comprehensive monitoring mechanisms protect the probe from thermal overloading. In the event of a malfunction, the probe is automatically removed from the rotary kiln by the retraction unit.

The harsh environmental conditions at the intake of the rotary kiln result in extreme loads on the sampling probe. The process gas temperature can be up to 1 400 °C, and the dust load up to 2 000 g/m³. Caked-on materials falling down from the kiln lining present a danger for the probe through mechanical overloading.

Depending on the raw material and the fuels used, an increasing amount of sulfur, alkali and chlorides can be expected in the flue gas, which in turn may result in caking of material on the probe jacket and the production of corrosive acids.

To achieve as high an availability as possible with a minimum amount of maintenance effort, the mounting location for the probe must be determined exactly. If you are not sure about the most favorable installation location, obtain support from the supplier.

Many problems frequently encountered when using a gas sampling function in a rotary kiln can be largely avoided using the FLK probe. As a result of the high gas sampling temperature of up to 200 °C, problems associated with caking on the probe jacket and blocking of the gas paths by condensation are significantly reduced compared to water-cooled sampling systems which only achieve a gas sampling temperature of approx. 90 °C.

Cleaning of the gas sampling equipment is carried out at regular intervals using pulsed compressed air. Prior to starting the back-flushing, the gas path to the gas analyzer is closed by means of a four-way ball valve. As a result of the self-cleaning effect during the rotation, the ball valve has significant advantages compared to a standard solenoid valve.

The cleaning cycle is executed in several steps:

- Cleaning of filter pipe in dust filter
- Cleaning of filter housing and probe
- Blowing of dust back into the rotary kiln.

A pressure switch in the compressed air valve manifold detects imminent blockages in the gas paths between the planned purging times, and initiates immediate purging by means of the control unit.

The quantity and hardness of the caking on the probe jacket can be extremely different with different types of rotary kiln. In addition to possible mechanical overloading of the probe, the temperature of the sampled flue gas drops as a result of the thermal insulation from the hot process gases. This results in condensation of the flue gas in the probe's sampling tube. If a temperature of 130 °C is fallen below, the sample gas pump in the analyzer cabinet is switched off as protection against the production of condensation. Caking must therefore be removed regularly.

In order to remove caking, the probe can be automatically retracted from the rotary kiln at regular intervals, initiated by the control unit of the sampling equipment and depending on the amount of caking. Caking is usually removed automatically from the probe jacket as a result of cooling down in the cold ambient air. When retracting and inserting the probe, cleaning of the probe jacket is supported by passing compressed air through nozzles in the kiln connection tube. In unfavorable cases, manual cleaning by the maintenance personnel may be necessary.

The numerous control and monitoring functions are made possible by the PLC.

Adaptation of the control parameters - such as purging frequency and duration - can be carried out at any time using the integrated operator panel.

Technical specifications

General information

Power supply	400 V 3AC +10 %/-15 %, 50 Hz 400 V 3AC +10 %/-15 %, 60 Hz Connected load: approx. 5.5 kVA If the delta voltage deviates, a single-phase supply must be provided in addition: 120 V 3AC +10 %/-15 %, 50 Hz 120 V 3AC +10 %/-15 %, 60 Hz 230 V 3AC +10 %/-15 %, 50 Hz 230 V 3AC +10 %/-15 %, 60 Hz Connected load: approx. 1.5 kVA Other voltages up to 500 V possible on request
Auxiliary media	
• Compressed air	6 000 ... 8 000 hPa, purified compressed air, free of oil, water and dust
• Flow	Approx. 4 ... 6 m ³ /h, depends on purging frequency and duration
Sample gas connection	8 mm pipe union, connection for heated or unheated sample gas line; required pump capacity at 700 hPa absolute approx. 2 to 5 l/min

Liquid-cooled sampling probe

Type	F6534-B12
Material	Stainless steel, mat. No. 1.4571
Length	1 000/1 500/2 000/2 500/3 000/3 500 mm (corresponds to immersion depth)
Sampling point	Dependent on installation: <ul style="list-style-type: none"> • E1 sampling point on left • E2 sampling point on right
Process temperature	Up to 1 400 °C
Coolant	Synthetic heat transfer liquid
Coolant flow rate	Max. 3 200 l/h
Weight	Approx. 150 kg

Electrically heated dust filter

Power supply	See General information
Filter	Sintered metal filter SIKA-R30 (3 µm for 98 %) Filters with smaller pore sizes available on request
Operating temperature	Approx. 200 °C, isolated contact for low temperature
Backflushing, two-stage (filter element and filter surface)	6 000 ... 8 000 hPa, purified compressed air, free of oil, water and dust
Compressed air connection	Filter enclosure ¾" Filter pipe ½"
Sample gas connection	
• Sample gas inlet	Male thread M24x1.5
• Sample gas outlet	Pipe union DN 8
Weight	Approx. 20 kg

Compressed air valve manifold

Power supply	See General information
Compressed air connection	6 000 ... 8 000 hPa, purified compressed air, free of oil, water and dust
Ambient temperature	Max. 70 °C
Maximum operating pressure	16 000 hPa
Pressure switch	800 ... 200 hPa absolute, adjustable for detection of low pressure
Dimensions (WxHxD) in mm	630 x 380 x 210
Weight	Approx. 40 kg

Retraction unit with electrical and pneumatic drive

Power supply	See General information
Drive	<ul style="list-style-type: none"> • Duplex chain drive, installed protected in carrier • Worm gear motor • Compressed air motor for emergency retraction on failure of power supply • Adjustment of product immersion depth possible using limit switch
Travel time	Approx. 90 s
Dimensions	Type 1: 3 780 mm for probe length 1 000 ... 1 500 mm Type 2: 5 300 mm for probe length 2 000 ... 3 500 mm
Weight	Approx. 420 kg

Heat exchange unit

Power supply	See General information
Heat output	Max. 65 kW
Coolant	Synthetic heat transfer liquid
Fill quantity	Approx. 25 l
Flow	Max. 3 200 l/h, adjustable
Operating temperature	<ul style="list-style-type: none"> • Inlet temperature of coolant 200 °C • Outlet temperature of coolant 170 °C
Dimensions (WxHxD) in mm	1 200 x 1 850 x 1 600
Weight	Approx. 400 kg

Control and monitoring unit

Power supply	See General information
Control voltage	24 V DC
Signals	Floating contacts to the host process control system
Dimensions (WxHxD) in mm	760 x 760 x 210
Weight	Approx. 60 kg

Analytical Application Sets

Set FLK

Dimensional drawings

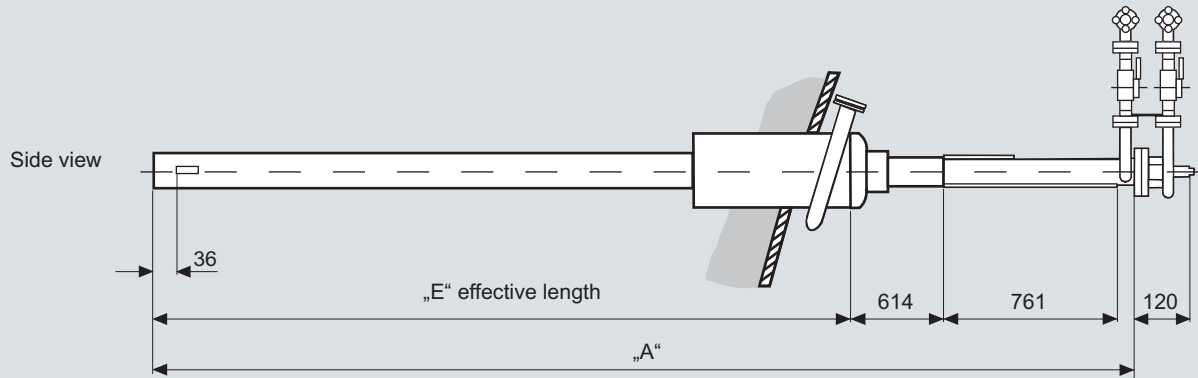

Top view	Model	Sampling opening	Model	"A"
	E1	left	E1 or E2	"A"
			3 000	4 500
			2 500	4 080
	E2	right	2 000	3 580
			1 500	3 080
			1 000	2 580

Example 3 000 E1
(probe length 4 580 mm, sampling opening left)

Liquid-cooled sampling probe, dimensions in mm

Selection and ordering data	Order No.
<p>FLK (liquid/air cooling) gas sampling system for rotary cement kilns. Compact design with heat transfer liquid cooling. Suitable for gas temperatures up to 1 400°C and dust loads up to 2 000 g/m³ Operating temperature of coolant circuit up to 220°C. Consisting of:</p> <ul style="list-style-type: none"> • Gas sampling probe • Dust filter • Automatic retraction unit with electrical and pneumatic drive • Backflushing equipment with condensation removal • Liquid/air heat exchange unit • Mounting accessories 	<p>7MB1951- ■■■■ - ■ AA 0</p>
<p><u>Control and monitoring unit</u> Fully wired and mounted in wall cabinet Dimensions (W x H x D): 1 000 x 1 400 x 300 mm Functions:</p> <ul style="list-style-type: none"> - Controlling removal of dust from probe and dust filter - Automatic probe retraction, time-controlled or in the event of a fault - Monitoring, processing and displaying sampling system fault and operational messages <ul style="list-style-type: none"> • Without control and monitoring unit • Control and monitoring unit with SIMATIC S7-300 	<p>0 1</p>
<p><u>Sampling probe</u> Made of stainless steel 1.4571 With side sampling point Standard lengths: 1 000, 1 500, 2 000, 2 500 and 3 000 mm immersion depth Special lengths on request</p> <ul style="list-style-type: none"> • Without sampling probe • Sampling probe 2 500 mm; sampling point on right • Sampling probe 2 500 mm; sampling point on left • Sampling probe 3 000 mm; sampling point on right • Sampling probe 3 000 mm; sampling point on left • Sampling probe 1 000 mm; sampling point on right • Sampling probe 1 000 mm; sampling point on left • Sampling probe 1 500 mm; sampling point on right • Sampling probe 1 500 mm; sampling point on left • Sampling probe 2 000 mm; sampling point on right • Sampling probe 2 000 mm; sampling point on left 	<p>A B C D E F G H J K L</p>
<p><u>Automatic oven flap</u> none With</p>	<p>A B</p>
<p><u>Power supply</u> 230 V/50 Hz 115 V/60 Hz 115 V/50 Hz 230 V/60 Hz</p>	<p>0 1 2 3</p>
<p><u>Documentation</u> English German</p>	<p>0 1</p>
<p><u>Backflushing equipment with condensation removal</u> Condensation remover integrated into backflushing equipment Condensation remover (enclosed separately) for mounting on analysis cabinet</p>	<p>0 1</p>

Analytical Application Sets

Set FLK

More information

Manual

FLK gas sampling system

Instruction Manual

- German
- English

On request

On request

Electrically heated dust filter

- German
- English

On request

On request

Valve manifold for probe purging

- German
- English

On request

On request

Retraction equipment

- German
- English

On request

On request

Startup and Servicing Manual

On request

Overview



The standardized Set GGA (Generator Gas Analyzer) has been specially designed for monitoring hydrogen-cooled turbo generators.

Benefits

Standardized complete system

- Simple and fast to configure
- Field-proven, harmonized and reliable set
- Low purchase price and economic operation
- Suitable for optimizing the efficiency of H₂-cooled turbo generators

Field-proven, reliable technologies

- High-precision and reliable purity monitoring of hydrogen
- Microchip-based thermal conductivity measurement
- Redundant measuring system
- SIL 1 certificate for the analysis hardware

Simple operation

- Intuitive menu prompting
- Configuration on large displays with plaintext
- Use of CO₂ and AR as inert gas possible

Application

This set is used in power generation applications.

Turbo generators in power plants are cooled with gas in order to increase their efficiency. In spite of the strict safety requirements hydrogen is used as a cooling gas. This offers huge advantages over air. These include considerably better cooling properties, lower friction loss on rotating parts, and a higher electrical breakdown strength. These features enable hydrogen to satisfy the requirements for the turbo generator to reach an optimum level of efficiency.

However, mixtures of hydrogen and air with a hydrogen content of anything from 4 to 77 % are explosive. For safety reasons, it is imperative that this is prevented during operation filling and emptying of the turbo generators. International standards (EN 60034-3 and IEC 842) state that redundant safety monitoring with two independent operating systems must be used for this.

In addition, contamination of the hydrogen cooling gas reduces the efficiency of the turbo generator, as it leads to considerably higher friction loss. For a 970 MW generator, a difference of 4 % is equivalent to a 0.8 MW difference in power. There are also good reasons related to cost-effectiveness why the cooling gas should be continuously monitored for contamination.

The Set GGA is a complete solution for monitoring hydrogen-cooled turbo generators, with the dual benefit of being simple to handle and having low initial investment costs.

Design

The Set GGA is available in the following versions:

- Generator Gas Analyzer (GGA)
- GGA with test gas skid
- GGA with test gas skid and installation frame

Analyzers

The GGA contains two CALOMAT 6E analyzers (19" rack unit versions). From the gas sampling system right through to the gas outlet, these are completely separate from one another, thereby ensuring full redundancy.

The CALOMAT 6E is a continuous gas analyzer for determining H₂ and He in binary or quasi-binary gas mixtures.

To measure the hydrogen and inert gases continuously, the exact thermal conductivity of the sample gas mixture is measured and the concentration calculated from this. Only binary gas mixtures can be directly measured.

The CALOMAT 6E is used to measure 0 to 100 % CO₂/Ar in air, 0 to 100 % H₂ in CO₂/Ar or 80 to 100 % H₂ in air, in the context of monitoring hydrogen-cooled turbo generators, on account of its high measuring range dynamics.

The units are approved for use in ATEX Zone 2. Gas mixtures may also be fed in according to the definition of Zone 1. In terms of tightness and compressive strength, the measuring cell and entire physical structure of the gas path, from inlet to outlet, are certified up to 55 000 hPa. This is much higher than the pressure that arises when oxyhydrogen gas is ignited.

A flame arrestor at the sample gas inlet provides additional safety.

The integrated LCD display shows the measured values, status bar and measuring ranges simultaneously.

The T90 time is less than 5 s. This means that the delay between the measurement and displaying the result is very short.

Tests carried out under harsh field conditions have indicated that the 3-week drift of the measurement results is less than 0.1 %. Combined with a repeatability value of 0.1 %, this ensures that the measurement results gathered will be both accurate and precise.

Analyzer cabinet

Another feature of the GGA is a protective cabinet for the analyzers. This provides a compact location where the system can be easily installed, and offers protection against dust and water. The system is approved in accordance with IP54 degree of protection.

The cabinet measures 616 x 615 x 600 mm (H x D x W) and is made from painted sheet steel.

A key advantage of this type of construction is that it eliminates the need for a restricted breathing enclosure, allowing maintenance to be carried out without any difficulty. If a restricted breathing enclosure is required, it must be ensured that the system is operated in an airtight room. Restoring the restricted breathing enclosure once maintenance procedures have been performed is a costly and time-consuming process.

To keep operating and maintenance costs low, the GGA set supports natural cabinet ventilation and a filter element provides protection against particles of dirt. Purging with instrument air is not necessary.

Test gas skid

The analyzers and analyzer cabinet are supplied as part of the basic configuration of the set. As an option, however, it is also possible to obtain a suitable test gas skid on a mounting plate.

The test gas skid is responsible for preparing the extracted sample ready for analysis. This ensures that the sample, calibration and inert gases are fed into the analyzers at the right pressure and flow rate, and without having been mixed with other gases.

The skid is fully equipped with a flame arrestor, stopcock ball valve, stainless steel overflow regulator, single-stage pressure reducer, stainless steel 5-way transfer ball valve, all-metal flow meter for air, 1-channel isolating switch amplifier and installation material. The flowmeters are designed to transmit a limit monitoring signal. The connection is made on-site.

The test gas skid guarantees that all the requirements in terms of safety, quality and simplicity are satisfied when connecting sample, calibration and inert gases.

Installation frame

The installation frame is a supplementary feature of the set. It enables free-standing installation of the analyzer cabinet and test gas skid.

The installation frame is supplied in a fully assembled state (including feet). Its overall height is 2 000 mm.

Function

There are three distinct processes in monitoring hydrogen-cooled turbo generators: normal operation, filling and emptying. The measuring task entails preventing a gas mixture of hydrogen and air outside the specified limits, or detecting the risk of this happening in good time, as well as monitoring the hydrogen purity.

During normal operation, the purity of the generator cooling gas is monitored. If the purity falls below a specific limit (e.g. < 95 % H₂), a message is output. The monitored range is 80 to 100 % H₂ in air.

Filling the generator is a two-stage procedure: first, the air in the generator is replaced by inert gas (argon or CO₂), and then this is replaced by hydrogen. During this, the concentration trends of the gases are measured and the replacement processes monitored. To prevent explosive mixtures from being formed, it is necessary to monitor the measuring range of 0 to 100 % inert gas in air in the first step and 0 to 100 % H₂ in inert gas in the second step.

The procedure is performed in reverse when emptying the generator: The hydrogen is first replaced with inert gas and the generator is then filled with air. The measuring tasks remain unchanged in this case. Here it is necessary to monitor the measuring ranges of 0 to 100 % H₂ in inert gas first, and then 0 to 100 % inert gas in air.

Technical specifications

Climatic conditions

Ambient temperature	5 ... 50 °C
Relative humidity	70 %, non-condensing
Corrosive atmosphere	No

Gas inlet conditions

• Calomat 6E	
- Sample gas pressure	800 ... 1 100 hPa (absolute)
- Sample gas flow	30 ... 90 l/h (0.5 ... 1.5 l/min)
- Sample gas temperature	0 ... 50 °C
• Test gas skid	
- Sample gas pressure	55 000 hPa (absolute)
- Sample gas flow	30 ... 90 l/h (0.5 ... 1.5 l/min)
- Sample gas temperature	0 ... 50 °C

Power supply

• Supply 1	200 ... 240 V AC
• Supply 2	100 ... 120 V AC
• Supply 3	24 V DC for switch amplifiers

Power supply, frequency

• Supply 1	47 ... 63 Hz
• Supply 2	47 ... 63 Hz
• Supply 3	Not specified

Type of connections

Pipe material	Stainless steel
Connections/components	• Metric (6 mm) • Imperial (1/4")

Cabling

Electrical design	According to IEC
Type of cables	Non-armored cables
Cable ID	No single core labeling

Installation

Site	Interior
Ex-zone analyzer	ATEX II, 3G

System design

Version	Cabinet
Degree of protection	IP54
Automatic calibration	No
Signal outputs	4 ... 20 mA/isolated contact Max. 24 V AC/DC 1 A
With sample gas return flow	On request

Measuring response

(relating to sample gas pressure 1 013 hPa absolute, 0.5 l/min sample gas flow and 25 °C ambient temperature)

Output signal fluctuation	< ± 0.75 % of the smallest possible measuring range according to rating plate, with electronic damping constant of 1 s ($\sigma = 0.25 %$)
Zero point drift	< 1 %/week of the smallest possible span according to rating plate
Measured-value drift	< 0.5 %/of the smallest possible span according to rating plate
Repeatability	< 1 % of the current measuring range
Detection limit	1 % of the current measuring range
Linearity error	< ± 1 % of the current measuring range

Influencing variable

(relating to sample gas pressure 1 013 hPa absolute, 0.5 l/min sample gas flow and 25 °C ambient temperature)

Ambient temperature	< 1 %/10 K referred to smallest possible span according to label
Carrier gases	Deviation from zero point
Sample gas flow	< 0.1 % of the smallest possible span according to rating plate with a change in flow of 0.1 l/h within the permissible flow range
Sample gas pressure	< 1 % of the current measuring range with a pressure change of 100 hPa
Power supply	< 0.1 % of the current measuring range with rated voltage ± 10 %

Generator gas analyzer

Analysis	Measuring point designation			Generator gas analyzer			
	Concentration			Unit	Measured component	Measuring range	
Component	Min.	Typical	Max.			Small	Large
Ar/CO ₂ in air	0		100	vol. %	Yes	0	100
H ₂ in Ar/CO ₂	0		100	vol. %	Yes	0	100
H ₂ in air	80		100	vol. %	Yes	80	100
Sample temperature		50		°C			
Dust content		0		mg/m ³			
H ₂ O dew point		-50		°C			
Aggregate state, sample ¹⁾	Gaseous						

¹⁾ Standard state at 20 °C, 101.3 kPa

Analytical Application Sets

Set GGA

Selection and ordering data

Set GGA

Gas connections

6 mm pipe

1/4" pipe

Version

H₂ monitoring (turbo generators)

Add-on electronics

Without

Auxiliary power

100 ... 120 V AC, 47 ... 63 Hz

200 ... 240 V AC, 47 ... 63 Hz

Variants

Generator Gas Analyzer (GGA)

GGA with calibration gas skid

PG solution in accordance with EMT674-057 (220 V, 6 mm, English/German)

PG solution in accordance with EMT674-059 (110 V, 6 mm, English/German)

GGA with calibration gas skid and installation frame

Explosion protection

Certificate: ATEX II 3G, flammable and non-flammable gases

Documentation

German

English

French

Spanish

Order No.

7MB1950-

0 -

Cannot be combined

0

1

GA

0

0

1

A

B

C

D

E

B

0

1

2

3

1

0

1

B

B

C

D

E

E

C

D

D

Dimensional drawings

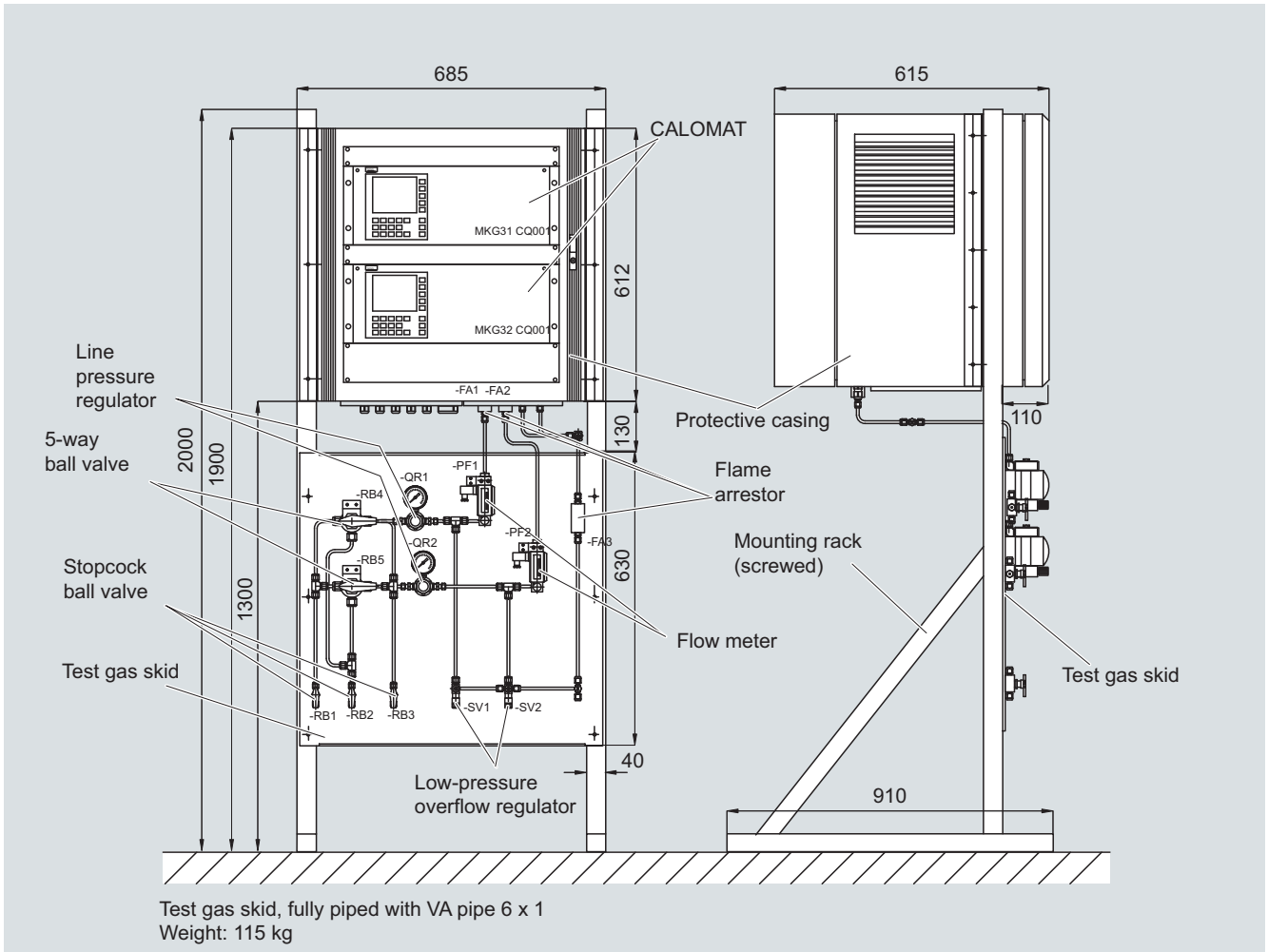

Set GGA, dimensions in mm, figure corresponds to 7MB1950-0GA00-1EB0

Overview



The Set CV (Calorific Value) is a standardized system for determining the quality of natural gas with SITRANS CV and MicroSAM.

Benefits

Standardized complete system

- Easily and quickly configured, from sampling to the gas supply
- Field-proven, harmonized and reliable set
- Suitable for determining the natural gas quality with high accuracy

Field-proven, reliable technologies

- Version with German Federal Testing Authority certification (without mass memory, without DSfG) available for fiscal metering
- GC MEMS technology with low consumption levels, high linearity/accuracy over the entire measuring range, and short cycle times

Easy installation

- Installation in EEx Zone 1 possible
- Compact and rugged design for erecting indoors and outdoors
- Minimum space requirements

Application

For the chromatography industry, the natural gas market is one of the fastest growing in the world. There are a variety of reasons for this. While global energy requirements are increasing, there is a parallel trend of fossil fuel reserves being depleted. Natural gas is one type of fossil fuel that can still be found in vast, untapped reserves. In addition to this, the market is becoming increasingly liberalized, and the number of participants has risen considerably as a result - from the production stage, across the entire distribution network, right through to the end customer. In turn, this has generated more transfer points at which the quality and quantity of natural gas need to be determined for accounting purposes.

The market requires a reliable complete system which is specially designed for natural gas. With the Set CV, Siemens offers a system that covers all the requirements of such applications, from sampling to pressure reduction, sample preparation and determination of quality, supplying carrier and calibration gases, right through to expansion of the communication interfaces. The set offers various modules to cover market requirements. Using the different versions, the set can be adapted, and the modules can be freely-combined.

Such a system can be used wherever the quality of natural gas has to be determined. For example, during the conditioning of natural gas and feeding into the pipeline network, during transportation and distribution in the network, and when extracting it for supply purposes.

Design

Standardization of systems means good clarity and simple facilities for configuration. Different versions mean that it is possible to appropriately adapt the system to the requirements. The modules can be combined as desired. Standardization also means that not all imaginable versions are included, and that special requirements such as armored cables, customer-specific documentation, specific conductor labeling, or certificates such as CE or 31B cannot be implemented at all, or not without an extra charge.

The design is divided into the following standard modules: sampling, pressure reduction, sample preparation system, SITRANS CV, gas supply, calibration gases.

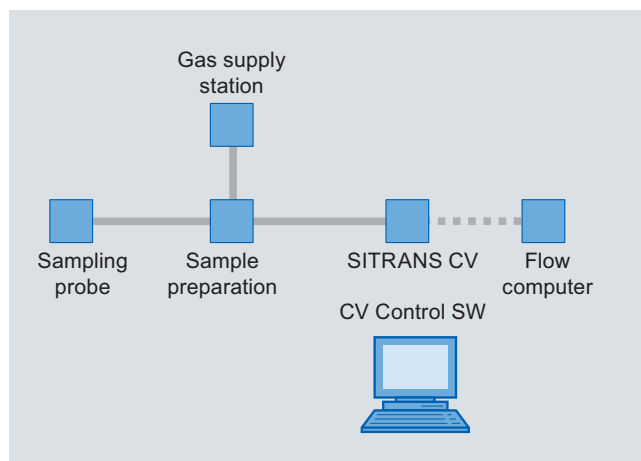

General information

The set can be dimensioned for a 230 V AC or 115 V AC power supply. It is not possible to switch between supplies.

The gas connections can be supplied with either metric or imperial dimensions.

On the metric line, the gas connections are in the form of metric clamping ring glands with a diameter of 3 mm. The imperial line contains gas connections in the form of imperial clamping ring glands with a diameter of 1/8 inch. The pipes between the sampling probe, pressure reduction, sample preparation device, and SITRANS CV are optionally available. The system is generally designed for temperatures between -20 and +55°C in areas with a risk of explosions. When provided with heating, the system can also be used down to -30 °C. The natural gas to be measured should be in a stable gaseous form, dry and clean.

Sampling probe

The basic components of a sampling probe are a lance, process connection, process isolation and, if necessary, pressure reduction. The high-pressure version is not supplied pre-assembled.

Lance

A representative sample should be taken from the central third of the pipeline. With a lance length of 1 m it is therefore possible to extract a sample from a pipeline with a diameter of up to 1 600 mm. In addition, two versions with different types of lance diameter are available. On the one hand, a pipe whose outer diameter is 6 mm and inner diameter is 2 mm. And on the other, a pipe whose outer diameter is 12 mm and inner diameter is 8 mm. The lance can be supplied in a permanently installed or removable state (not for 12 mm).

Process connection

There are four versions for the flange connection to the pipeline. Flange DN 65 PN16 Form C for pressures up to 1 600 kPa, flange ANSI 2" for pressures up to 300 lbs RF as well as flange DN 65 PN160 Form E for pressures up to 16 000 kPa and flange ANSI 2" for pressures up to 2 500 lbs RF

Process isolation

It may be necessary to isolate the natural gas line from the system for maintenance and repair work. To do this, you can select either a simple stopcock or a double block and bleed structure. While the stopcock is a cost-effective solution for minimum requirements, the double block and bleed structure stands for enhanced safety, as it has two valves that prevent any gas from being transferred further.

High-pressure reduction on the primary side

Pressure can be reduced in three ways: directly at the probe (primary side), in an external casing with a pressure reduction unit (primary side), or in the sample preparation system (secondary side).

If the sample preparation system and the natural gas chromatograph are installed directly next to the sampling point, the high-pressure reduction can be implemented in the sample preparation system. The pressure should always be reduced as close to the sampling point as possible in order to keep the dead volume as small as possible. The sample and calibration gas pressures must be reduced to between 10 and 500 kPa. The sample gas pressure must be at least 200 kPa less than the carrier gas pressure. The carrier gas pressure should be between 600 and 700 kPa.

Heated and unheated pressure reduction units are available in the external casing for high-pressure reduction on the primary side. Pressure reduction in the external casing is suitable for combination with the permanently installed and retractable standard probe. The heated pressure regulators have a power consumption of 150 W, and reliably maintain the sample in a gaseous state.

Special probe with high-pressure reduction

A third option offers an alternative to the two standard probes: a permanently installed probe with integrated separation of aerosols (so-called BTU diaphragm) in the pipeline and a pressure reduction unit. The lance is integrated in this at a depth of 228 mm. The protection pipe has an outer diameter of 22.8 mm. The lance and pressure reduction do not need to be separately defined.

Heated pipeline

To ensure that the sample is maintained in a gaseous state, it is recommendable to use a heated sample gas line – for example, between the sampling point and the sample preparation system. The pipeline is encased in a PE corrugated hose with an outer diameter of 43 mm. The self-regulating maintenance temperature remains at approximately 80 °C. The electrical connection is in the terminal box.

The power consumption is approx. 38 W/m.

Pipe base for enclosure attachment

A hot-dip galvanized 2" pipe base, 1 700 mm high, with mounting brackets and joining sheet enables free-standing mounting of the protective casing.



Sample preparation

Generally speaking, the sample pressure must be reduced to between 10 and 500 kPa. The flow should be between 20 and 100 ml/min. It is important that the pressure is 200 kPa below the carrier gas pressure. The carrier gas pressure should be between 600 and 700 kPa.

The basic configuration of the sample preparation system for a stream includes a stopcock, 0.5 µm filter, flowmeter for the fast loop, pressure-relief valve (set to 100 kPa), 3/2-way solenoid valve with sealed cable for automatic switching between calibration gas and sample gas, and a terminal box for connecting the solenoid valve. This solenoid valve must either be protected by the customer at 0.5 A, or a ready-assembled terminal box with power supply and fuses can be ordered from the list of supplementary items.

There are also a number of other options for modifying the basic configuration.

Secondary pressure adjustment

The pressure adjustment unit with unheated pressure regulators can be ordered for one, two and three sample flows. This type of structure meets the minimum secondary pressure adjustment requirements. Please note that a reduction in pressure cools the sample down considerably, which can cause moisture to condense if the dew point is fallen below.

Another alternative, however, is pressure adjustment with a heated pressure regulator (150 W) for one, two or three sample streams. Heating the sample ensures that it remains in a gaseous state. The Joule-Thomson effect is thus compensated. The regulators can reduce pressures from 16 to 100/170 kPa.

If the pressure is to be reduced directly at the sampling probe or in an external casing outside the sample preparation system, no further pressure reduction is required during sample preparation.

Analytical Application Sets

Set CV

4

Sample injection

Where sample injection is concerned, straightforward and safety versions are available for between one and three streams.

Considered simply, sample injection is carried out for one, two or three streams using one solenoid valve per sample stream (cascade connection). Its job is to block any gas flows that are not required without preventing the desired gas from flowing. A 0.5 A fuse is required per solenoid valve and flowmeter. These are available in the ready-assembled terminal box.

The safety version of the sample injection system for one, two or three streams with double block and bleed technology enables the sample to be switched over, which in turn allows clean separation between gas streams by partially closing and venting the line. Since two valves are used to prevent the flow of gas that is not to be measured, rather than just one, the functional safety of the system remains at an optimum level for a long time. In addition, 0.5 A fuses are required for the sample valves and calibration valve. These are included in the electrical connection (supplementary item).

Monitoring the sample gas monitoring chromatograph (GC)

The sample flow to the GC can also be monitored electronically as an option. An alarm signal is output when necessary. A switch disconnecter for the power supply is also required; this can be ordered along with the ready-assembled terminal box.

Protective casing/mounting plate for sample preparation system

The sample preparation system is available mounted either on a plate, in the protective casing, or in the heated protective casing.

The stainless steel mounting plate, measuring 652 x 422 x 3 mm (H x W x D), is suitable for wall mounting. The system components selected are mounted on the plate and supplied with all pipes and wires installed.

The unheated protective transmitter box, made from fiber glass-reinforced plastic and suitable for wall mounting measures 750 x 520 x 430 mm (H x W x D) and is fitted with stainless steel hinges, quick-release locks, safety glass windows and a stainless steel mounting plate.

The system components selected are mounted and supplied with all pipes and wires installed in the protective casing.

It is also possible to provide a heater in the protective transmitter box which can be controlled between 10 and 40 °C in steps of 5. The system components selected are mounted and supplied with all pipes and wires installed in the protective casing. The heating has a power of 300 W.

Aerosol filter/glycol filter

These filters have the task of removing any impurities that may have been introduced into the natural gases by aerosols or glycols, thus providing an additional level of safety for the SITRANS CV and, therefore, the system functionality. The aerosol filter is supplied with 5 replacement diaphragms and the glycol filter with 10 replacement cartridges.

Manual laboratory sampling

An additional control valve permits manual laboratory sampling as an option. When not in use, it is fitted with a blanking plug on the output end.

Pipe base for enclosure attachment

A hot-dip galvanized 2" pipe base, 1 700 mm high, with mounting brackets and joining sheet enables free-standing mounting of the protective casing or the mounting plate as an alternative to wall mounting.

Protective top cover

Another option is a protective top cover made from fiber glass-reinforced plastic and supplied with mounting brackets, for protection against solar radiation and storms. It must be mounted to a pipe base.

Heated sample gas line

To prevent condensation of the sample, it may be necessary to use a heated prepared pipeline – for example, between the sample preparation device and SITRANS CV/MicroSAM. The pipeline is encased in a PE corrugated hose with an outer diameter of 43 mm. The self-regulating maintenance temperature is around 80 °C.



Example of single-stream sample preparation system: may deviate from the supplied system

SITRANS CV/MicroSAM

The core component of the Set CV is the GC SITRANS CV/MicroSAM (for more detailed information see catalog PA 01, section 3).

SITRANS CV/MicroSAM system components

Protective casing/plate for SITRANS CV/MicroSAM

The SITRANS CV/MicroSAM is available mounted either on a plate, in the protective casing, or in the heated protective casing.

The stainless steel mounting plate, measuring 652 x 422 x 3 mm (H x W x D), is suitable for wall mounting.

The unheated protective transmitter box, made from fiber glass-reinforced plastic and suitable for wall mounting measures 750 x 520 x 430 mm (H x W x D) and is fitted with stainless steel hinges, quick-release locks, safety glass windows and a stainless steel mounting plate.

The protective casing can also be supplied with heating as an option. The heating can be adjusted between 10 and 40 °C, in increments of 5. The system components selected are mounted and supplied with all pipes and wires installed in the protective casing. The heating has a power of 300 W.

Terminal box

There are five connection options in total to choose from.

The simplest option is the interface in accordance with SITRANS CV/MicroSAM (open cable end).

The terminal box measuring 340 x 170 x 91 mm (H x W x D) is made from polyester resin. The scope of delivery includes terminals, isolating terminals, cable glands and a PE rail. If ordered with the pipe base add-on part, the terminal box is supplied attached to the base, and the scope of supply includes 2.5 mm² terminals for connection by the customer and M16/M20 cable glands. The power supply is 24 V DC. The terminal box is not suitable for connecting a heater, flow meter with limit value transmitter, and Double Block and Bleed (DB&B).

The terminal box measuring 360 x 360 x 190 mm (H x W x D) is made from painted sheet steel. The scope of delivery includes switch amplifiers, terminals, and cable glands. If ordered with the pipe base add-on part, the terminal box is supplied attached to the base, and the scope of supply includes 2.5 mm² terminals for connection by the customer and M16/M20 cable glands. The power supply is 24 V DC. The terminal box is not suitable for connecting a heater and DB&B.

The terminal box, including switch amplifier and a power supply (115 V AC or 230 V AC, not switchable), measuring 360 x 360 x 190 mm (H x W x D), is made from painted sheet steel. The scope of delivery includes terminals, 0.5 A fuses, terminals, cable glands and a PE rail. If ordered with the pipe base add-on part, the terminal box is supplied attached to the base, and the scope of supply includes 2.5 mm² terminals for connection by the customer and M16/M20 cable glands. The terminal box is not suitable for using DB&B.

The terminal box, including switch amplifiers and a power supply (115 V AC or 230 V AC, not switchable), measuring 360 x 360 x 190 mm (H x W x D), is made from painted sheet steel. The scope of delivery includes isolating terminals, 0.5 A fuses, terminals, cable glands, relays and a PE rail. If ordered with the pipe base add-on part, the terminal box is supplied attached to the base, and the scope of supply includes 2.5 mm² terminals for connection by the customer and M16/M20 cable glands.

Gas supply

A gas chromatograph requires calibration and carrier gases. Therefore the set offers various options with regard to gas connection, gas cylinder design, and calibration gases. Either individual components or complete systems can be ordered.

Cylinder pressure reducer, separate

The cylinder pressure reducer for calibration gases is supplied separately. It is made from stainless steel and has a cylinder connection conforming to DIN 477 No. 14 (calibration gas). The cylinder pressure reducer is also fitted with a gauge for primary and back pressure.

Contact gauge for supply gases

Two gauges with a 50 mm diameter and mounted on the battery pressure reduction station can also be ordered. The intrinsically-safe slot initiators in accordance with NAMUR must be operated via a switch amplifier. This is not included in the delivery. The line is in the terminal box on the station panel.

Heated line

A heated prepared line is available for heating the calibration gas line from the cylinder cabinet to the sample preparation device. The power consumption is 38 W/m with an outer diameter of 43 mm on the corrugated hose. The integrated heating system is self-regulating with a maintenance temperature of approximately 80 °C.

Automatic cylinder changeover switch with separate coils

The stainless steel automatic cylinder changeover switch, supplied on a mounting plate, is designed for back pressures of between 50 and 1 000 kPa and contains two coiled pipes for helium that conform to DIN 477. The maximum permissible cylinder pressure is 20 000 kPa. This version also includes a gauge for measuring primary and back pressure. A contact gauge cannot be fitted when supplied separately.

Simple supply unit

This simple supply unit consists of a hot-dip galvanized 2-inch pipe base, 2 200 mm high, with a fiber glass-reinforced plastic protective top cover as well as two cylinder holders and a cylinder changeover switch. The gas cylinders are not included in the basic scope of supply.

Painted sheet steel gas cylinder cabinet

This version is supplied with the automatic cylinder changeover switch and coils, as well as the stainless steel calibration gas cylinder pressure reducer in a sheet metal cabinet.

The gas cylinder cabinet has room for two 50 l cylinders and one 10 l calibration gas cylinder. The dimensions are 2 050 x 1 250 x 400 mm (H x W x D). It contains the cylinder station, a stopcock for carrier gas, cylinder holder and pipe coils for the gas cylinders. The cabinet pipes are fully installed and the cabinet is equipped with bulkhead fittings for carrier gas, calibration gas and exhaust gas from the pressure relief valves.

As an option, this gas cylinder cabinet can also be supplied with heating from a heating sleeve for a 10 l calibration gas cylinder at 20°C retaining temperature. The cylinder head is heated separately, in a fiber glass-reinforced plastic enclosure. The cylinder pressure reducer is also located here. The heating sleeve prevents condensation from building up in the gas cylinder. To ensure seamless gas heating, a heated line for removing the calibration gas is recommended.

Calibration gases

Six different calibration gases are available as standard.

Component groups	C6+ with O ₂	C6+ without O ₂	C6+ without O ₂	C7+ without O ₂	C6, C7, C8, C9 without O ₂	Bio-methane with H ₂
Special feature		Certified in acc. with PTB-A 7.63				
	(mol %)	(mol %)	(mol %)	(mol %)	(mol %)	(mol %)
Hydrogen						0.20
Nitrogen	4.00	4.00	4.00	4.00	4.00	4.00
Carbon monoxide						
Carbon dioxide	1.50	1.50	1.50	1.50	1.50	2.50
Oxygen	0.50					0.40
Methane	88.40	88.90	88.90	88.80	88.86	88.40
Ethane	4.00	4.00	4.00	4.00	4.00	2.50
Ethene						
Propane	1.00	1.00	1.00	1.00	1.00	1.00
Isobutane	0.20	0.20	0.20	0.20	0.20	0.50
n-butane	0.20	0.20	0.20	0.20	0.20	0.50
Neopentane	0.05	0.05	0.05	0.1	0.1	
Isopentane	0.05	0.05	0.05	0.05	0.05	
n-pentane	0.05	0.05	0.05	0.05	0.05	
n-hexane	0.05	0.05	0.05	0.05	0.01	
n-heptane				0.05	0.01	
n-octane					0.01	
n-nonane					0.01	

PTB-certified version SITRANS CV Set

One version of the Set CV described above has been tested by the Physikalisch Technisch Bundesanstalt (PTB, German Technical Inspectorate) and approved for fiscal metering.

The SITRANS CV Set version approved for fiscal metering consists of a single-stream sample preparation system with stopcock, unheated pressure regulator, 0.5 µm filter, DB&B 3/2-way solenoid valves, flowmeter with limit signal transmitter, fitted on a mounting plate and pipe base. The SITRANS CV is also fitted on a mounting plate and pipe base. Further components are a terminal box and the CV Control natural gas analyzer software. This certified version is also designed for indoor installation. The room temperature should not fall below 5 °C or exceed 55 °C. The certificate does not include a DSfG interface or mass storage unit.

The PTB-certified system can be ordered from catalog PA 01, section 3 (see SITRANS CV (7KQ3105-0 in connection with GWK-CHRPACV-CER-1)).

Function

It is the job of the sampling probes to take a representative sample from the pipeline. It is important to ensure that this sample is extracted from the central third of the pipeline. One advantage of the retractable probes is that there is no risk of damage being caused to them when pigging is taking place in the pipeline. There is also the option of reducing pressure directly at the sampling probe. This is especially advisable if sample preparation and gas analysis are not carried out directly next to the sampling point.

As a general rule, implementing a reduction in pressure reduces the sample pressure to between 10 kPa and 500 kPa. Heated pressure regulators must be used if the dew point could be fallen below in the process.

In the sample preparation system, pressure reducers and flowmeters can be used to set the sample flow and pressure that will ultimately be required. Electronic monitoring of the sample flow transmits an alarm signal to the SITRANS CV/MicroSAM if necessary. The filters ensure that the sample is appropriately clean. An optional double block and bleed (DB&B) arrangement of the solenoid valves can ensure extremely safe isolation between the sample streams and the calibration gas. All versions of the sample preparation system are available for one, two or three flows plus the calibration flow.

The prepared sample is then analyzed in the natural gas analyzer and the calorific value, standard density and Wobbe index are calculated. Connecting the SITRANS CV/MicroSAM to a flow computer enables an energy value to be calculated from the measured quality and quantity with consideration of the pressure, temperature and flow measurement. SITRANS CV is preferably used in connection with flow computers. For the use of MicroSAM, please consult the parent company.

In order to regularly carry out calibration and supply carrier gas to the SITRANS CV/MicroSAM, gases that are typically found in shelving or cabinet structures must be made available. Heating the gas cylinders prevents condensation from building up in them. The gas cylinder transfer station enables the cylinders to be exchanged during operation. Individual cylinders can be connected and disconnected by means of valves.

The communication functionalities of the SITRANS CV can be extended using a SIMATIC Extension Unit. It is then possible to connect a further Modbus master and/or up to 16 AO. For the generation of analog outputs in combination with MicroSAM, we recommend the I/O Extender solution (see catalog PA 01, section 3)

Technical specifications

General information

Ambient temperature	-30 ... 55 °C (with heating)
Explosion protection	CENELEC Category 2G, T3
Supply voltage	230 V AC, 115 V AC or 24 V DC
Max. permissible pressure at input of high-pressure reduction	16 000 kPa
Max. permissible pressure at input of sample preparation system with pressure regulator	16 000 kPa
Max. permissible pressure at output of sample preparation system	10 ... 500 kPa, min. 200 kPa below carrier gas pressure Optimum carrier gas pressure 600 ... 700 kPa

Sampling

Lance	Outer diameter 6 mm and inner diameter 2 mm or outer diameter 12 mm and inner diameter 8 mm Length 1 000 mm
Special probe with BTU diaphragm and pressure reduction, non-retractable	Immersion depth approx. 380 mm Protection pipe outer diameter 25.4 mm
Process connection	At flange DN65 PN16 Form C, max. 1 600 kPa gas pressure At flange DN65 PN160 Form E, max. 16 000 kPa gas pressure At flange ANSI, 2-inch, 300 lbs RF At flange ANSI, 2-inch, 2 500 lbs RF
High-pressure reduction in casing with pressure regulators, optional heating	Casing with dimensions 385 x 485 x 380 mm Primary pressure 16 000 kPa, output pressure 100/170 kPa (power consumption 150 W)
Pipe base	2-inch pipe base for free-standing transmitter box, 1 700 mm high
Heated line	Heating power is 38 W per meter Self-regulating heating up to approx. 80 °C Outer material is PE corrugated hose with 43 mm outer diameter

Sample preparation for 1 to 3 sample gas flow, plus calibration gas flow

Basic configuration	0.5 µm filter, 3/2-way solenoid valve, flowmeter, overflow valve and stopcock
Pressure regulator, optional heating	Primary pressure 16 000 kPa, output pressure 100/170 kPa (power consumption 150 W)
Simple sample injection	One 3/2-way solenoid valve per sample gas stream
DB&B sample injection	Two 3/2-way solenoid valves per sample gas flow
On mounting plate	652 x 422 x 3 mm
In protective casing	750 x 520 x 430 mm
Protective casing heating	Power consumption 300 W Adjustable between 10 and 40 °C, in increments of 5
Pipe base	2-inch pipe base, 1 700 mm high
Additional filters	Aerosol, glycol

System components

On mounting plate	650 x 422 x 3 mm
In protective casing	750 x 520 x 430 mm
Protective casing heating	Power consumption 300 W Adjustable between 10 and 40 °C, in increments of 5.
Terminal box	340 x 170 x 91 mm
Pipe base	2-inch pipe base, 1700 mm high
Heated line	Heating power is 38 W per meter Self-regulating heating up to approximately 80 °C Outer material is PE corrugated hose with 43 mm outer diameter

Gas supply

Transfer station	Max. cylinder pressure 20 000 kPa Output pressure 50 ... 1 000 kPa
Pipe base	2-inch pipe base, mounted Height 2 200 mm
Gas cylinder cabinet	Gas cylinder cabinet for two 50 l carrier gas cylinders and one 10 l calibration gas cylinder. Dimensions are 1 250 x 400 x 2 050 mm
Cylinder heating	The cylinder heating system is dimensioned for 10 l calibration gas cylinders and ensures that no condensation occurs within the gas cylinder.
Cylinder pressure reducer	Cylinder pressure reducer for reducing primary pressure of max. 30 000 kPa to back pressure 0 ... 400 kPa
Heated line	Heating power is 38 W per meter Self-regulating heating up to approximately 80 °C Outer material is PE corrugated hose with 43 mm outer diameter

Calibration gas

Gas mixture 1 ... 6	The gas mixture is stable for 36 months.
---------------------	--

Analytical Application Sets

Set CV

4

Selection and ordering data	Order No.
CV set, probe (supplied separately) and high-pressure reduction	7KQ2150- - - - - Cannot be combined
<u>Explosion-proof version, in accordance with CENELEC</u>	0
<u>Supply voltage</u>	
Without	A
230 V AC	B
115 V AC	C
<u>Pneumatic connections</u>	
Metric	A
Imperial	B
<u>Lance (length always 1 m)</u>	
Without	0
OD/ID 6 mm/2 mm	1
OD/ID 12 mm/8 mm	2
<u>Process connection</u>	
Without	0
Flange DN65 PN16 Form C	1
Flange DN65 PN160 Form E	2
Flange ANSI, 2", 300 lbs RF	3
Flange ANSI, 2", 2 500 lbs RF	4
<u>Analysis isolation</u>	
Without	0
Stopcock	1
DB&B	2
<u>Probe installation</u>	
Without	A
Standard (without pressure reduction)	B
Removable (without pressure reduction)	C
Special installation (with pressure reduction)	D
<u>High pressure reduction</u>	
Without	A
Separate high-pressure reduction box with mech. pressure regulators	B
Separate high-pressure reduction box with evaporation pressure regulator	C
Additional versions	Order code
Add "-Z" to Order No. and specify order code	
Base for high-pressure reduction device	B01
Protective top cover GRP	B02
Preparation of heated line	B03
Heated line from the high-pressure reduction box to the sample preparation device (C03 + C03 = 2 m)	C03
Separate stainless steel pipe 3 x 0.5 mm in 5 m intervals for connection to the sample preparation device (example: C04+C04 = 10 m)	C04

Selection and ordering data	Order No.	
Sample preparation device, basic configuration	7KQ2151-	Cannot be combined
<u>Explosion-proof version, in accordance with CENELEC</u>	0	
<u>Supply voltage</u>	A	A A A
Without	B	
230 V AC	C	
115 V AC		
<u>Pneumatic connections</u>	A	
Metric	B	
Imperial		
<u>Pressure adjustment</u>	0	
Without	1	
Pressure regulator unheated for 1 sample flow	2	
Pressure regulator unheated for 2 sample flows	3	
Pressure regulator unheated for 3 sample flows	4	4
Pressure regulator heated for 1 sample flow	5	5
Pressure regulator heated for 2 sample flows	6	6
Pressure regulator heated for 3 sample flows	7	
Sample gas pump (Ex) für 1 sample flow		
<u>Sample injection</u>	0	
Without	1	
Standard for 1 sample flow (automatic)	2	
Standard for 2 sample flows (automatic)	3	
Standard for 3 sample flows (automatic)	4	4
For 1 sample flow in DB&B technology (automatic)	5	5
For 2 sample flows in DB&B technology (automatic)	6	6
For 3 sample flows in DB&B technology (automatic)		
<u>Monitoring the sample gas flow to the gas chromatograph</u>	0	
Visual, mechanical monitoring	1	
With electrical monitoring		
<u>Plate/enclosure</u>	A	
Without	B	
Mounting plate for wall mounting	C	
GRP protective casing (unheated) for wall mounting	D	D
GRP protective casing (heated) for wall mounting	E	
GRP protective casing (unheated) mounted on base	F	F
GRP protective casing (heated) mounted on base	G	
Mounting plate mounted on base		
Additional versions	Order code	
Add "-Z" to Order No. and specify order code		
Aerosol filter per sample flow with 5 replacement diaphragms	A01	
Glycol filter per sample flow with 10 replacement cartridges	A02	
Manual lab sampling per sample flow	A03	
Connection of second calibration gas through solenoid valve	A04	
Protective top cover GRP	B01	
Replacement filter element for sample flow filter (5 units)	E01	

Analytical Application Sets

Set CV

4

Selection and ordering data	Order No.	
System components	7KQ2152- ■■■■	Cannot be combined
<u>Explosion-proof version, in accordance with CENELEC</u>	0	
<u>Supply voltage</u>	A	
230 V AC	B	
115 V AC	C	C C C → B03, C01
24 V DC		
<u>Pneumatic connections</u>	A	
Metric	B	
Imperial		
<u>Plate/enclosure SITRANS CV</u>	0	
Without	1	
On plate, with stopcock and connection pieces	2	
In the GRP protective casing, unheated	3	3
In the GRP protective casing, heated		
<u>Electrical connection</u>	0	
Interface in accordance with technical data of SITRANS CV (free cable end)	1	
Ex terminal box with standard terminals; 24 V DC connection	2	
Ex terminal box with electrical sample gas monitoring; 24 V DC connection	3	3
Ex terminal box with electrical sample gas monitoring and standard sample injection; 115/230 V AC connection	4	4
Ex terminal box with electrical sample gas monitoring and DB&B sample injection; 115/230 V AC connection		
<u>Additional versions</u>	Order code	
Add "-Z" to Order No. and specify order code		
Pipe bases for securing the enclosure without mounting plate/box	B01	
Protective top cover GRP	B02	
Preparation of heated line	B03	
Heated line for sample preparation device/SITRANS CV (C01+C01=2 m)	C01	
Installation kit (pipe/glands/cable) for connecting to the sample preparation device	C02	
Separate stainless steel pipe 3.0 x 0.5 mm or 3.18 x 0.56 mm (continuous) at 5 m intervals (example: C03+C03+C03=15 m)	C03	

Selection and ordering data	Order No.	
Gas supply	7KQ2153-	Cannot be combined
<u>Explosion-proof version, in accordance with CENELEC</u>	0	
<u>Supply voltage</u>	A	A → C01
Without	B	
230 V AC	C	
115 V AC		
<u>Pneumatic connections</u>		
Metric	A	
Imperial	B	
<u>Automatic transfer station (stainless steel) with coils</u>		
Without	0	
Installed on the mounting panel	1	
Installed on the base	2	
Installed in the metal cabinet	3	
Installed in the metal cabinet with calibration gas cylinder heating	4	
<u>Cylinder pressure reducer for calibration gas</u>		
Without	0	
Separate	1	
Installed (base/metal cabinet)	2	
Additional versions	Order code	
Add "-Z" to Order No. and specify order code		
2 contact pressure gauges for transfer station	A01	
Preparation of heated line	B03	
Heated line for calibration gas from the cylinder cabinet to the sample preparation device (only with 115 V/230 V); length per meter (C01+C01 = 2 m)	C01	
Separate stainless steel pipe 3.0 x 0.5 mm or 3.18 x 0.56 mm (continuous) at 5 m intervals (example: C02+C02+C02= 15 m)	C02	

Selection and ordering data	Order No.	
Calibration gas for SITRANS CV	7KQ2158- 0 A 0 0	
<u>Calibration gas in 10 liter cylinder</u>		
Mixture 1	B	
Mixture 2	C	
Mixture 3	D	
Mixture 4	E	
Mixture 5	F	
Mixture 6	G	

Overview



The Set CEM 1 is a standardized system specially for monitoring the emission components in flue gases.

Benefits

Standardized complete system

- Highly exact and reliable monitoring of emission components in flue gases. System-specific certificate according to DIN EN ISO 14956 and QAL 1, according to EN 14181.
- Modular complete package with gas sampling system, sample gas preparation system and gas analyzers from one source
- Simple and fast to configure
- Tried and tested, harmonized and reliable set
- Low purchase price and economic operation

Proven, suitability-tested technologies

- Continuous determination of up to eight measured components
- In-situ measurements without sampling and preparation, using LDS 6 laser diode spectrometer
- Use of ULTRAMAT 23 with cleanable cells and automatic calibration with ambient air as well as optional electrochemical oxygen measurement

Optional:

- Paramagnetic oxygen measurement with OXYMAT 6

Simple operation

- Intuitive operation
- Configuration on large displays using plain text, in several languages

Simple maintenance

- Maintenance-friendly cabinet design with hinged frame and uniform design
- Digital display of maintenance requests on LOGO modules

Application

The monitoring of emission components in flue gases is one of the most important topics for continuous gas analysis. This is a result of legislation for monitoring emissions, e.g. for large combustion plants, and also due to the requirements of companies operating process plants who can draw conclusions on the process efficiency from the gas analyses, e.g. with boiler control, DENOX and DESOX plants.

The market requires a reliable complete system which is specially designed for the application. The Set CEM 1 (Continuous Emission Monitoring) offered by Siemens is a system which reliably covers all requirements associated with sampling, sample preparation, and gas analysis.

It is possible to determine the concentrations of the gaseous components CO, CO₂, NO, NO_x, SO₂, O₂, C_{total}, HCl, HF, NH₃ and H₂O.

The ULTRAMAT 23 and OXYMAT 6 are used for the extractive, continuous gas analysis.

The standardized Set CEM 1 provides great clarity and simple configuration facilities. Different versions mean that it is possible to appropriately adapt the system to the requirements. Standardization also means that not all imaginable versions can be included, and that it may not be possible to implement special requirements such as armored cables, varying gas compositions, customer-specific documentation or specific conductor labeling without an extra charge.

Design

Starting with a mounting frame with sample preparation system, it is possible to add additional units as options. These include:

- Sampling probe with weather protection hood
- Heated sample gas line (for details see catalog PA11)
- Analyzers
- Air-conditioning unit
- NO₂/NO converter
- Sample preparation extension for an additional ULTRAMAT 23 analyzer
- Single and dual (electrically isolated, not electrically isolated) analog signal processing
- Power supply modules (115 V, 230 V, 400 V)
- Outer panels with steel-plate door or with window
- Single-pole and double-pole fusing
- Condensation bottle
- Coalescence filter

Sampling probe

The standard probe is fitted with a DIN flange DN 65, PN 6. The probe is provided with a regulated heater, and has a power consumption of 400 VA. It is supplied with a weather protection hood and 2 µm filter. The maximum dust concentration at the sampling point should not exceed 2 g/m³. The sampling pipe is 1 000 mm long, is made of stainless steel, and has dimensions of 20 x 1.5 mm. The sample gas temperature must not exceed 600 °C.

It is also possible to purchase the Set CEM 1 without sample probe.

Heated sample gas line

The temperature of the heated line is regulated at 200 °C by a temperature controller. The power consumption is 100 VA per meter. The internal core is made of PTFE 4/6. The heated line can be up to 35 m in length. Lengths greater than 35 m can be provided upon special request. If desired, the system can also be supplied without a heated sample gas line.

Mounting frame

The basis of each CEM 1 set is the mounting frame with hinged frame (40 HU) for installation of up to five 19" rack units. The mounting frame includes a standardized sample preparation system designed for an ULTRAMAT 23.

The sample preparation system includes a 3/2-way solenoid valve, 3-way switchover ball valve, regulating valve, corrosion-resistant sample gas pump (power consumption 60 VA), condensation trap, room air suction filter with filter element, LOGO for digital display of individual signals in the cabinet, 24 V DC power supply unit (power consumption 70 VA). Also included are a sample gas cooler (power consumption 200 VA) with integral heat exchanger, hose pump, moisture sensor with flow cell and Teflon filter. Teflon tubes connect the components.

The external dimensions without plinth are 2 000 x 800 x 800 mm (H x W x D). A cabinet depth of 600 mm is also optionally available (not suitable for LDS 6). Hoses and cables can be connected from the left or right. A distance of 500 mm must be provided on the left or right at the installation site for introduction of the hoses and cables.

In addition to the sheet-steel mounting frames for indoor installation, an FRP version is also available for outdoor use. The FRP cabinet is always provided complete with side panels and plinth. The external dimensions are 2 080 x 800 x 600 mm (H x W x D). The GRP cabinet cannot be combined with the LDS 6.

Preparation of sample preparation system for second ULTRAMAT 23

The standard system with sample preparation system and electronics is prepared for one ULTRAMAT 23. If a second ULTRAMAT 23 is to be fitted, this option must be selected so that the sample preparation system and electronics are extended accordingly.

Additional filter

In addition to the fine filter and moisture filter which are always present, a coalescence filter can be optionally fitted in the sample preparation system.

Side panels with doors

Optional outer panels can be selected for the sheet-steel mounting frames. This possibility allows use of the CEM 1 set in analysis cabinets as a rack design on one hand, or on the other as a cabinet design in halls requiring degree of protection IP54. Either a sheet-steel door without window or a glass door can be selected.

Base

Plinths with a height of 100 and 200 mm are additionally available.

Cabinet cooling and ventilation

Optionally available are a fan with outlet filter, an air-conditioning unit for indoor installation, and an air-conditioning unit for outdoor installation. The system can be ordered without a fan or air-conditioning unit if the side panels and the door with window are omitted.

The fan with outlet filter has a power consumption of 60 VA, and is fitted in the cabinet wall. The delivery also includes a thermostat with a power consumption of 25 VA.

The air-conditioning unit has a cooling power of 820 VA.

Frost protection heater

The power consumption of the optional cabinet heater is 500 VA. The delivery includes a thermostat with a power consumption of 25 VA for controlling the frost protection heater.

Fusing of the analog signals

In addition to single-pole fusing of the electronic consumers, it is possible to provide double-pole fusing.

The double-pole fuse is mainly required in Benelux countries.

Removal of condensation

A 19 liter condensation bottle can be provided as an option. It is also possible to order the system without a condensation bottle if the condensation can be removed on-site.

NO₂/NO converter

The mounting frame and cabinets can be optionally extended by a 19" rack unit with NO₂/NO converter with carbon cartridge. The power consumption is 520 VA. The flow rate is 90 l/h. An NO₂/NO converter is required if the share of NO₂ in the total NO_x is greater than 5 % and/or if total NO_x is to be always determined.

Power supply

The system can be designed either for 115 V AC, 230 V AC or 400 V AC (-15 %, +10 %) with 50 or 60 Hz.

Three phases, neutral and ground must be provided by the customer at 400 V AC.

Analog signal processing

As standard, the analog signals are simply connected to isolating terminals. As an option, the analog signals can be processed twice without electrical isolation by a diode module, or twice with electrical isolation.

Analyzers

The standardized set is prepared for an ULTRAMAT 23. The system can be supplemented by a second ULTRAMAT 23, OXYMAT 6 and/or LDS 6. Various measured components and measuring ranges can be selected. Other combinations of measured components and measuring ranges are available on request, but you must check that the desired certificates and approvals are available. The analyzers, measured components and measuring ranges used are described briefly below.

Details on the analyzers, alternative components and ranges can be found under the topics "Continuous gas analyzers, extractive" and "Continuous gas analyzers, in-situ".

ULTRAMAT 23: CO, NO

For measuring two infrared components.

Component	Smallest tested measuring range	Switchable to
CO	0 ... 150 mg/Nm ³	0 ... 750 mg/Nm ³
NO	0 ... 100 mg/Nm ³	0 ... 500 mg/Nm ³

One or two measuring ranges can be freely set within the limits. The ULTRAMAT 23 carries out automatic self-calibration with ambient air. The power consumption is 60 VA.

Analytical Application Sets

Set CEM

Set CEM 1

ULTRAMAT 23: CO, NO, SO₂

For measuring three infrared components.

Component	Smallest tested measuring range	Switchable to
CO	0 ... 250 mg/Nm ³	0 ... 1 250 mg/Nm ³
NO	0 ... 400 mg/Nm ³	0 ... 2 000 mg/Nm ³
SO ₂	0 ... 400 mg/Nm ³	0 ... 2 000 mg/Nm ³

One or two measuring ranges can be freely set within the limits. The ULTRAMAT 23 carries out automatic self-calibration with ambient air. The power consumption is 60 VA.

ULTRAMAT 23: CO, NO, CO₂

For measuring three infrared components.

Component	Smallest tested measuring range	Switchable to
CO	0 ... 250 mg/Nm ³	0 ... 1 250 mg/Nm ³
NO	0 ... 400 mg/Nm ³	0 ... 2 000 mg/Nm ³
CO ₂	0 ... 5 %	0 ... 25 %

One or two measuring ranges can be freely set within the limits. The ULTRAMAT 23 carries out automatic self-calibration with ambient air. The power consumption is 60 VA.

The component CO₂ has not been type approved by the TÜV.

ULTRAMAT 23: CO₂

For measuring one infrared component.

Component	Smallest measuring range	Largest measuring range
CO ₂	0 ... 5 %	0 ... 25 %

One or two limits can be freely set within the limits. The ULTRAMAT 23 carries out automatic self-calibration with ambient air. The power consumption is 60 VA.

The component CO₂ has not been type approved by the TÜV.

The ULTRAMAT 23 analyzers can be optionally equipped with an electrochemical oxygen sensor.

O₂: Tested measuring ranges 0 to 10 / 25 %

OXYMAT 6: O₂

For paramagnetic measurement of oxygen. Instead of ULTRAMAT 23 with electrochemical cell.

O₂: Tested measuring ranges 0 to 10 / 0 to 25 %

Sample chamber without flow-type compensation branch, made of stainless steel 1.4571.

LDS 6: HCl

Component	Smallest tested measuring range
HCl	0 ... 15 mg/Nm ³

Application for channel 1: Emission monitoring

The power consumption is 50 VA. Suitable for connection of non-Ex sensors, including non-Ex-protected sensor electronics.

The delivery includes a pair of sensors for instrument air or N₂ on the process side. The pair of sensors is designed for a moderate flow rate of 0 to 120 l/min. The 400 mm long purging tubes are made of stainless steel. The process connection is DN 65, PN 6. The power consumption is 2 VA.

Limitation:

Applies to measurement paths > 2 000 mm, applies to gases with a methane content < 15 mg/m³. Necessary gas temperature between 120 and 210 °C.

LDS 6: HCl / H₂O

Component	Smallest tested measuring range
HCl	0 ... 15 mg/Nm ³

Component	Smallest tested measuring range
H ₂ O	0 ... 30 %

Application for channel 1: Emission monitoring

The power consumption is 50 VA. Suitable for connection of non-Ex sensors, including non-Ex-protected sensor electronics.

The delivery includes a pair of sensors for instrument air or N₂ on the process side. The pair of sensors is designed for a moderate flow rate of 0 to 120 l/min. The 400 mm long purging tubes are made of stainless steel. The process connection is DN 65, PN 6. The power consumption is 2 VA.

Limitation:

Applies to measurement paths > 2 000 mm, applies to gases with a methane content < 15 mg/m³. Necessary gas temperature between 120 and 210 °C.

LDS 6: HF

HF: Smallest possible measuring range depends on the gas composition.

Application for channel 1: Emission monitoring

The power consumption is 50 VA. Suitable for connection of non-Ex sensors, including non-Ex-protected sensor electronics.

The delivery includes a pair of sensors for instrument air or N₂ on the process side. The pair of sensors is designed for a moderate flow rate of 0 to 120 l/min. The 400 mm long purging tubes are made of stainless steel. The process connection is DN 65, PN 6. The power consumption is 2 VA. The HF measurement has not been type approved by the TÜV.

Limitation:

Component has not been type approved by TÜV. Necessary gas temperature between 0 and 150 °C.

LDS 6: HF/H₂O

HF: Smallest possible measuring range depends on the gas composition.

H₂O: Smallest tested measuring range 0 to 30 %

Application for channel 1: Emission monitoring

The power consumption is 50 VA. Suitable for connection of non-Ex sensors, including non-Ex-protected sensor electronics.

The delivery includes a pair of sensors for instrument air or N₂ on the process side. The pair of sensors is designed for a moderate flow rate of 0 to 120 l/min. The 400 mm long purging tubes are made of stainless steel. The process connection is DN 65, PN 6. The power consumption is 2 VA. The HF measurement has not been type approved by the TÜV.

Limitation:

Component has not been type approved by TÜV. Necessary gas temperature between 0 and 150 °C.

LDS 6: NH₃

Component	Smallest tested measuring range
NH ₃	0 ... 20 mg/Nm ³

Application for channel 1: Emission monitoring

The power consumption is 50 VA. Suitable for connection of non-Ex sensors, including non-Ex-protected sensor electronics.

The delivery includes a pair of sensors for instrument air or N₂ on the process side. The pair of sensors is designed for a moderate flow rate of 0 to 120 l/min. The 400 mm long purging tubes are made of stainless steel. The process connection is DN 65, PN 6. The power consumption is 2 VA.

Limitation:

Applies to measurement paths > 1 250 mm. Necessary gas temperature between 0 and 150 °C.

LDS 6: NH₃/H₂O

Component	Smallest tested measuring range
NH ₃	0 ... 20 mg/Nm ³
H ₂ O	0 ... 15 %

Application for channel 1: Emission monitoring

The power consumption is 50 VA. Suitable for connection of non-Ex sensors, including non-Ex-protected sensor electronics.

The delivery includes a pair of sensors for instrument air or N₂ on the process side. The pair of sensors is designed for a moderate flow rate of 0 to 120 l/min. The 400 mm long purging tubes are made of stainless steel. The process connection is DN 65, PN 6. The power consumption is 2 VA.

Limitation:

Applies to measurement paths > 1 250 mm. Necessary gas temperature between 0 and 150 °C.

Hybrid cable

A hybrid cable is required to connect a central unit to one pair of sensors. Versions for 5, 10, 25, 40 and 50 m are available. Cable lengths cannot be combined. Lengths greater than 50 m can be ordered on request.

Sensor cable

A sensor cable is required to connect one pair of sensors. Versions for 5, 10 and 25 m are available. Cable lengths cannot be combined. Lengths greater than 25 m can be ordered on request.

Electrical preparation for dust measurement

Electrical preparation for connection of an external dust measurement to the system (contains a switch amplifier).

Electrical preparation for flow measurement

Electrical preparation for connection of an external flow measurement to the system (contains a switch amplifier).

Electrical preparation for pressure measurement

Electrical preparation for connection of an external pressure measurement to the system (contains a switch amplifier).

Electrical preparation for temperature measurement

Electrical preparation for connection of an external temperature measurement to the system (contains a switch amplifier).

Electrical preparation for emission data memory on rail module

On request.

Electrical preparation for emission data memory in 19" rack unit

On request.

Additional LOGO for four or more 19" rack units

Sets with more than three 19" rack units integrated require a LOGO extension module. The delivery also includes connection and programming.

Core end labeling

It is optionally possible to order core end labeling according to the Siemens standard (VDE 0100 Part 200).

Documentation

The Siemens standard documentation is available in German or English.

The documentation includes gas path diagram, circuit diagram, terminal diagram, installation diagram, consumable materials list, signal list, cable list, and parts list. Also included are technical data sheets and Operating Instructions for the components and devices used. The documentation language for parts provided by other suppliers may deviate. Plant description, LOGO program and test certificates are also included in the documentation.

The documentation contains no customer-specific/project-specific drawings, and consists of two folders and one CD per set.

Analytical Application Sets

Set CEM

Set CEM 1

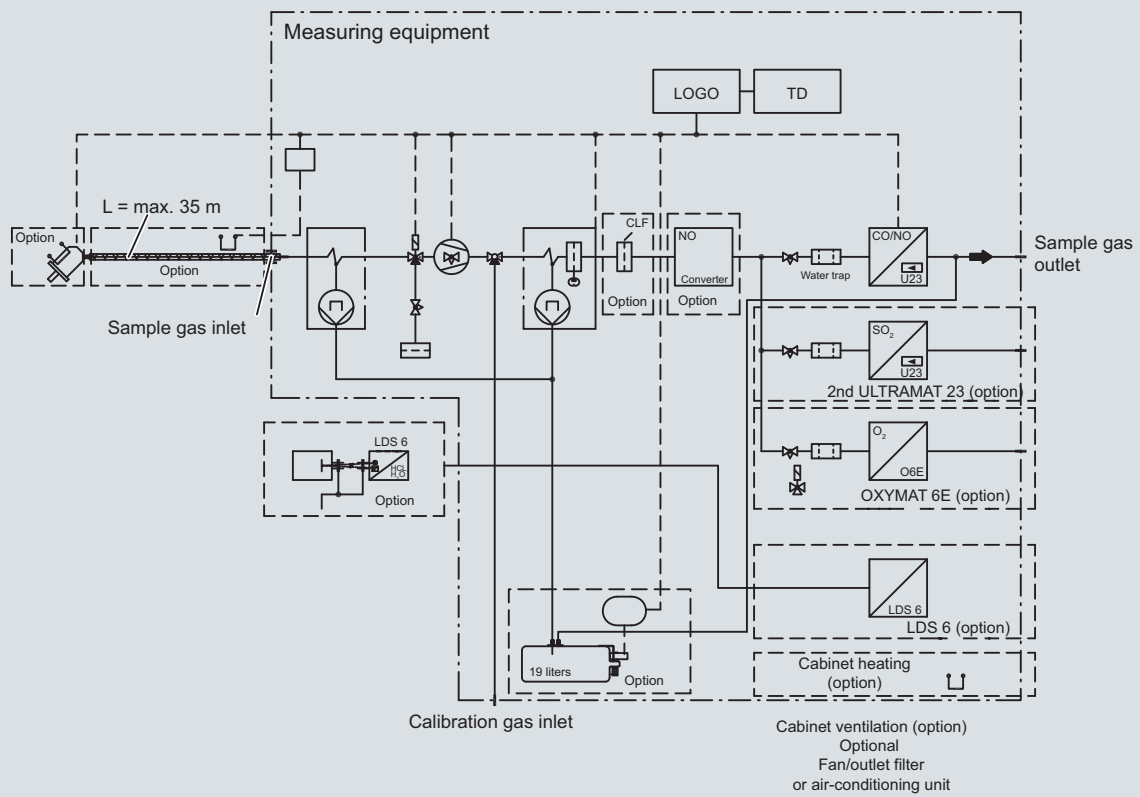

Figure contains options

Function

A sample is extracted via the heated sample gas probe. The dust concentration may be up to 2 g/m³, the sample gas temperature up to 600 °C. The gas is transported to the analysis cabinet via a heated sample gas line. The heating prevents condensate. The gas cooler cools and dries the sample in the analysis cabinet. Condensate is drained. The level in the condensate trap is monitored. For safety purposes, a coalescence filter can be provided in addition to the fine filter and moisture filter which are always present. The sample gas is analyzed by analyzers such as the ULTRAMAT 23, OXYMAT 6 and LDS 6. The ULTRAMAT 23 operates on the basis of molecular-specific absorption of infrared radiation or with an electrochemical oxygen measuring cell. The OXYMAT 6 is an analyzer for paramagnetic oxygen measurements. The in-situ LDS 6 laser diode spectrometer operates according to the molecular-specific absorption of near-IR radiation. The delivery may also include an NO₂/NO converter which permits measurement of total nitrogen oxides. In order to qualify the set for low or high temperature ranges (-5, +45 °C), it is possible to use a cabinet heater or air-conditioning unit. Power supply versions are available for 115, 230 or 400 V AC. Electronic consumers can be provided with single-pole or double-pole fusing. The components of the sample preparation system and the analyzers are connected to LOGO modules via a binary signal, and transmit maintenance requirements. The analog signals can be processed either singly or twice. Electrical isolation is additionally possible for the double processing.

Technical specifications

Climatic conditions

Ambient temperature	0 ... 35 °C
• With heater in sheet-steel cabinet	Min. -5 °C
• With heating in GRP cabinet	Min. -15 °C
• With air-conditioning	Max. 55 °C
Relative humidity	70 %, non-condensing
Corrosive atmosphere	No

Gas inlet conditions

Max. sample gas pressure at inlet to sample preparation system	500 hPa (mbar)
Max. moisture content in sample gas	17 vol-% ¹⁾
Max. water dew point	60
Min. sample gas pressure at inlet to sample preparation system	180 °C
Dust content at inlet to sample preparation system	Dust-free
Sampling probe	Sampling tube 20 x 1.5, 1 000 mm long, stainless steel, flange: DN 65, PN 6
Max. sample gas pressure at sampling probe	500 hPa (mbar)
Max. sample gas temperature at sampling probe	600 °C
Max. dust content at sampling probe	2 g/Nm ³

Sample gas must not be flammable or explosive.

Power supply

Supply 1	115 V AC (-15 %, +10 %)
Supply 2	230 V AC (-15 %, +10 %)
Supply 3	400 V AC (-15 %, +10 %)

Connections

Hose material	Teflon
Cables	Not armored, not halogen-free
Electrical design	According to IEC
Cable ID	Individual core labeling as option
Fusing of electronic consumers	1-pole; 2-pole as option
Duplication of analog signals	<ul style="list-style-type: none"> • Not electrically isolated as option • Electrically isolated as option

Installation

Site	<ul style="list-style-type: none"> • In sheet-steel cabinet/frame • In GRP cabinet 	<ul style="list-style-type: none"> Indoor installation Outdoor installation
Ex zone		Non-Ex area

System design

Type	Mounting frame or cabinet
Cabinet degree of protection	IP54
Automatic calibration	Yes, with ULTRAMAT 23

Detailed information on the analyzers

You can find detailed information on the analyzers:

- In the "Continuous Gas Analyzers, extractive" chapter
 - ULTRAMAT 23
 - OXYMAT 6
- In the "Continuous Gas Analyzers, in-situ" Chapter
 - LDS 6

Dimensions (without plinth)

Depth of sheet-steel frame	
• 800 mm (without plinth)	2 000 x 800 x 800 mm (H x W x D)
• 600 mm (without plinth)	2 000 x 800 x 600 mm (H x W x D)
GRP cabinet (with plinth)	2 080 x 900 x 600 mm (H x W x D)

It is necessary to provide a 500 mm gap to the right or left for the tube or cable inlet.

Use of the LDS 6 requires a cabinet with a depth of 800 mm.

¹⁾ Higher performance sample gas coolers can be offered upon request (not TÜV suitability-tested). A higher performance cooler is generally required for high sulfide content in fuels (e.g. heavy oil).

Analytical Application Sets

Set CEM

Set CEM1

Selection and ordering data

Set CEM 1 – Continuous Emission Monitoring

Order No.

7MB1953-

Cannot be combined

Rack

Rack 1: 2 000 x 800 x 800 mm (H x W x D), with sample preparation device, with hinged frame 40 HU, hose/cable inlet on left side, with lighting, prepared for 1 x ULTRAMAT 23, max. five 19" rack units possible

0

A03, A04, B02, B04

Rack 2: 2 000 x 800 x 800 mm (H x W x D), with sample preparation device, with hinged frame 40 HU, hose/cable inlet on right side, with lighting, prepared for 1 x ULTRAMAT 23, max. five 19" rack units possible

1

A03, A04, B02, B04

Rack 3: 2 000 x 800 x 600 mm (H x W x D), with sample preparation device, with hinged frame 40 HU, hose/cable inlet on left side, with lighting, prepared for 1 x ULTRAMAT 23, max. five 19" rack units possible, not suitable for LDS 6

2

A01, A02, B01, B03,
E01 ... E06,
F01 ... F06,
G01 ... G04

Rack 4: 2 000 x 800 x 600 mm (H x W x D), with sample preparation device, with hinged frame 40 HU, hose/cable inlet on right side, with lighting, prepared for 1 x ULTRAMAT 23, max. five 19" rack units possible, not suitable for LDS 6

3

A01, A02, B01, B03,
E01 ... E06,
F01 ... F06,
G01 ... G04

Rack 5: 2 060 x 900 x 600 mm (H x W x D), GRP, base 80 mm, with sample preparation device, with hinged frame 40 HU, hose/cable inlet on left side, with lighting, prepared for 1 x ULTRAMAT 23, with side panels, incl. door with window, max. five 19" rack units possible, not suitable for LDS 6

4

A01 ... A04,
B01 ... B04,
E01 ... E06,
F01 ... F06,
G01 ... G04

Rack 6: 2 060 x 900 x 600 mm (H x W x D), GRP, base 80 mm, with sample preparation device, with hinged frame 40 HU, hose/cable inlet on right side, with lighting, prepared for 1 x ULTRAMAT 23, with side panels, incl. door with window, max. five 19" rack units possible, not suitable for LDS 6

5

A01 ... A04,
B01 ... B04,
E01 ... E06,
F01 ... F06,
G01 ... G04

Sampling probe

Without

A

Standard sampling probe

B

Ventilation/cooling

Without

A

Fan with outlet filter

B

Cabinet air-conditioning unit

C

Cabinet air-conditioning unit for GRP rack

D

Heating

Without

0

Cabinet heating

1

Fuse protection

1-pole

0

2-pole (standard in Benelux countries)

1

Removal of condensation

Without

0

19 l container with level monitoring

1

NO₂/NO converter

Without

A

NO₂/NO converter

B

Power supply

115 V AC, -15 %, +10 %, 50 or 60 Hz

A

230 V AC, -15 %, +10 %, 50 or 60 Hz

B

400 V AC, -15 %, +10 %, 50 or 60 Hz (3 phases, neutral, ground provided by customer)

C

Connection set for heated line

Without controller

0

Standard controller (max. 35 m heated line can be connected)

1

Note:

The heated sample gas line must be ordered separately using Catalog PA 11.

<i>Additional versions</i>	Order code
Add "-Z" to Order No. and specify order code	
Bases	
Base for rack 1, 2, height 100 mm	A01
Base for rack 1, 2, height 200 mm	A02
Base for rack 3, 4, height 100 mm	A03
Base for rack 3, 4, height 200 mm	A04
Rack accessories	
Outer panel painted, for rack 1 and 2, viewing door	B01
Outer panel painted, for rack 3 and 4, viewing door	B02
Outer panel painted, for rack 1 and 2, sheet steel door	B03
Outer panel painted, for rack 3 and 4, sheet steel door	B04
ULTRAMAT 23, OXYMAT 6 extractive analyzers	
ULTRAMAT 23: CO, NO	C01
ULTRAMAT 23: CO, NO, SO ₂	C02
ULTRAMAT 23: CO, NO, CO ₂	C03
ULTRAMAT 23: CO ₂	C04
ULTRAMAT 23: Electrochemical O ₂ sensor for ULTRAMAT 23 expansion	C05
OXYMAT 6: OXYMAT paramagnetic O ₂ analyzer	C06
Additional sample preparation components	
For another ULTRAMAT 23	D01
Coalescence filter	D02
LDS 6 in-situ analyzers	
HCl including sensor pair	E01
HCl/H ₂ O including sensor pair	E02
HF including sensor pair, not suitability-tested	E03
HF/H ₂ O including sensor pair, not suitability-tested	E04
NH ₃ including sensor pair	E05
NH ₃ /H ₂ O including sensor pair	E06
LDS 6 hybrid cable per LDS 6	
5 m	F01
10 m	F02
25 m	F03
40 m	F04
50 m	F05
Customer-specific > 50 m	F06
LDS 6 connecting cable per LDS 6	
5 m	G01
10 m	G02
25 m	G03
Customer-specific > 25 m	G04
Electrical preparation	
Preparation for dust measurement	J01
Preparation for flow measurement	J02
Preparation for pressure measurement	J03
Preparation for temperature measurement	J04
Preparation for emission data memory – DIN rail module (on request)	J05
Preparation for emission data memory – 19" rack unit (on request)	J06
Additional LOGO	
LOGO for a third and fourth 19" rack unit	K01

Overview



Gasmet CEMS is another FTIR-based, standardized complete system for continuous, simultaneous measurement of a large number of emission components in flue gases from power stations and waste incinerators.

Benefits

Standardized complete system

- Highly accurate and reliable monitoring of emission components in flue gases
- Modular complete package with gas sampling system, hot sample processing, measurement at 180 °C, data processing and analysis
- Numerous analog and digital signal I/Os
- Simultaneous multicomponent analysis of 16 gas components as standard:
CO, CO₂, HCl, HF, H₂O, NH₃, NO, NO₂, N₂O, SO₂, CH₄, C₂H₄, C₂H₆, C₃H₈, C₆H₁₄, HCOH
- Additionally calculated from the FTIR measurement: NO_x and total carbon values
- Approval for FTIR-based emission measurements (QAL 1 in accordance with EN 14181) possible for ten measured components
- Can be expanded with one or two additional analyzers for measuring oxygen and for FID-based total carbon measurement (also with QAL 1 approval, if required)
- Simple and fast to configure
- Tried and tested, harmonized and reliable set
- Low purchase price and economic operation

Proven, performance-tested technologies

- Continuous determination of up to eleven measured components
- Simultaneous FTIR measurement for CO, CO₂, HCl, H₂O, NH₃, NO, NO₂, N₂O and SO₂
- Optionally: Use of a QAL1 certified ZrO₂ oxygen analyzer with hot sample feed
- Optionally: FID-based total organic carbon measurement with FIDAMAT 6

Simple operation

- Intuitive operation
- Configuration on a large TFT display using keyboard

Easy maintenance

- Maintenance-friendly cabinet design with 19" telescopic rails
- Digital display of maintenance requirements

Application

The measurement and monitoring of emission components in flue gases is one of the most important topics for continuous gas analysis. This is a result of legislation for monitoring emissions, e.g. for waste incinerators, and also due to the requirements of companies operating process plants who can draw conclusions on process efficiency from the gas analyses, e.g. with boiler and oven controls, DeNO_x and DeSO_x plants.

The market requires a reliable complete system which is specially designed for the application. The Gasmet CEMS (Continuous Emission Monitoring System) offered by Siemens is an extractive and continuous gas probe measuring system based on established FTIR spectroscopy method. It reliably covers all requirements associated with sampling, sample processing, and gas analysis.

The concentration of the following gas components can be determined on the basis of FTIR: CO, CO₂, HCl, HF, H₂O, NH₃, NO, NO₂, N₂O, SO₂, CH₄, C₂H₄, C₂H₆, C₃H₈, C₆H₁₄ and HCOH. The FTIR measurement can also be used to derive additional values for total organic carbon and NO_x. In addition, the Gasmet CEMS offers space for an optional ZrO₂ oxygen analyzer as well as a FIDAMAT 6 for determining total organic carbon levels (also QAL1 certified, if required).

The standardized Gasmet CEMS provides great clarity and simple configuration facilities. Different versions facilitate individual adaptation to the system requirements in hand. Standardization, however, also means that not all imaginable versions can be included, and that it may not always be possible to implement particular requirements such as armored cables, customer-specific documentation or special conductor labeling without an extra charge.

Design

The Gasmet CEMS is a fully equipped FTIR analysis system comprising several 19" slide-in units:

- A sampling unit with sample gas pump and controller for the heated sample gas lines,
 - internally, from the sampling unit to the analyzer (included in the scope of supply)
 - externally, from the sampling probe to the analysis cabinet (optional)
- The actual FTIR spectrometry system with gas cuvette
- An industrial PC as analysis and operator input unit, including keyboard and TFT display

Options for expanding the system include:

- A sampling probe
- A heated sample gas line (from the sampling probe to the analysis cabinet)
- Additional analyzers (maximum 2)
 - ZrO₂ oxygen analyzer
 - FIDAMAT 6 for total carbon measurement

Sampling probe

The Gasmet CEMS is supplied as standard without a sampling probe.

A suitable stainless steel (SS 316) probe with DN 65 PN 6 flange that can be heated to 180 °C is recommended as a sampling probe for the Gasmet CEMS. This can be offered separately on request.

Since particles of dust can usually be expected in sample gas, you are strongly recommended to use a sampling probe with a suitable (pre-)filter element and/or backflushing facility, especially with dust concentrations > 2 g/m³.

The sample gas temperature should usually not exceed 600 °C; the sample gas pressure must be between 400 and 6 000 hPa.

For performance-tested applications, a sampling probe matched to the Gasmet CEMS must be used (e.g. M&C SP2000H or comparable). This can be offered separately on request.

Heated sample gas line

The Gasmet CEMS is supplied as standard with heated sample gas lines between the sampling unit in the Gasmet CEMS analysis cabinet and the FTIR analyzer.

Further internal sample gas lines to the optional ZrO₂ and/or FID analyzers can be ordered additionally.

The external sample gas line from the sampling probe to the sampling unit in the analysis cabinet of the Gasmet CEMS is not included in the standard scope of delivery of the system.

All heated sample gas lines (external and internal) are regulated to 180 °C in the temperature controller integrated into the Gasmet CEMS sampling unit.

The external sample gas line can be heated as required and must therefore be designed for approx. 200 °C. It must have a power consumption of 120 VA per meter, and it must use K-type temperature sensors (Ni-Cr-Ni). The length of the heated line must not exceed 35 m.

Lengths greater than 35 m can be provided on special request, or they can be implemented via an additional temperature control unit.

For the external, heated sample gas line, a replaceable inner lining made from PTFE with a 4 mm inner diameter and 6 mm outer diameter is recommended. The connections must be Swagelok 6 mm.

Gasmet CEMS sampling unit

The sampling unit is designed for hot-extractive sampling of wet, corrosive gas streams, and is integrated into the Gasmet CEMS as a 19" slide-in unit.

It encompasses all valves, flow meters, sample gas pumps and filters required for the measuring task. The temperature of all parts coming into contact with the sample gas (pumps, filters and lines) is stabilized to 180 °C.

The sample gas does not have to be diluted and does not have to be dried beforehand either. The gas flow and the pressure of the instrument air supply can be monitored via the Gasmet CEMS sampling unit by means of an alarm.

The sampling unit is connected to the control PC and is controlled using the Calcmet software, like the FTIR and the other (optional) analyzers.



Gasmet CEMS sampling unit with removed filter insert

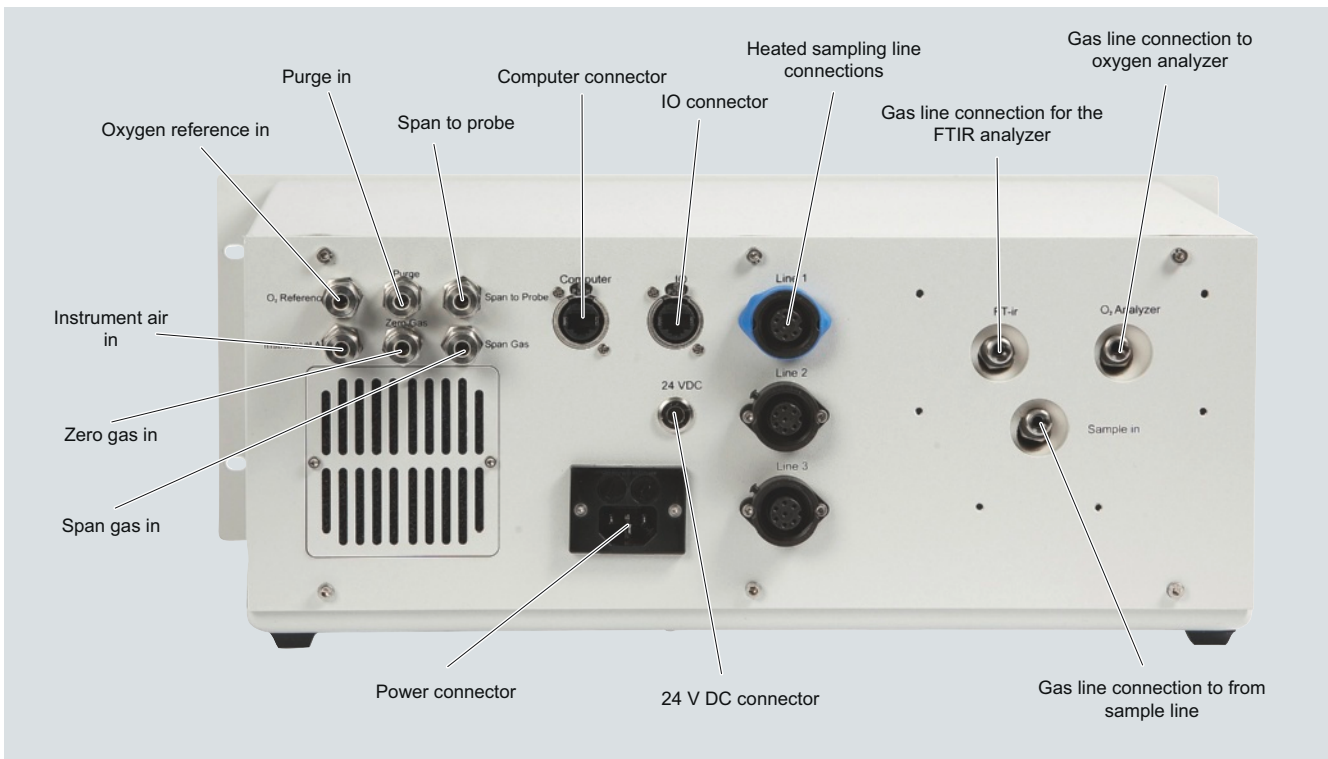

Rear with connections of the Gaset CEMS sampling unit

Analysis cabinet

The analysis cabinet of the Gaset CEMS contains all the essential components in the form of 19" slide-in units, including cabling and tubing:

- The Gaset CEMS sampling unit
- The Gaset CEMS FTIR spectrometry module with gas cuvette
- An industrial PC, including TFT display and keyboard, for controlling the analysis systems and for processing data
- An optional oxygen analyzer
- An additional, optional FIDAMAT 6 analyzer

The external dimensions of the analysis cabinet with socket, including the air-conditioning unit mounted on the rear door, are: 2 100 x 600 x (800 + 250) mm (H x W x D).

Hose and cable inlets are possible from the top, below, left and right.

At the installation location, sufficient space must be provided to the front, the right and the rear of the analysis cabinet to allow opening of the front and rear doors, and facilitate access to the rear door. The air-conditioning unit mounted on the rear also requires sufficient space for air circulation.

To be able to pull out the 19" slide-in units to the front on the telescopic extensions, the electrical cables and sample gas lines in the cabinet must be sufficiently long and flexible. The same applies to the lines to the CEMS analysis cabinet if it has to be moved on optional rollers for service and maintenance purposes, for example.

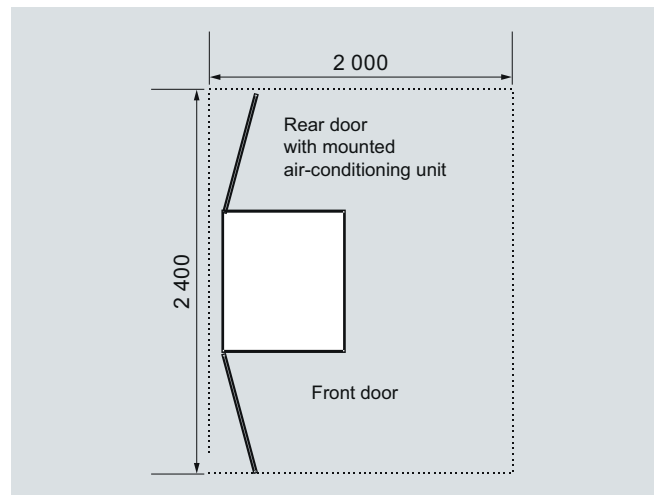

Minimum space requirements for a Gaset CEMS for facilitating installation and maintenance work

Analytical Application Sets

Gasmet CEMS

External panels and doors

The side panels and the rear door of the Gasmet CEMS analysis cabinet are designed in steel plate, and the front door in glass.

Base

The analysis cabinet of the Gasmet CEMS is offered optionally on a plinth or four rollers (two with immobilizing brakes).

Air-conditioning unit

To prevent overheating of the electronic components inside the cabinet, the analysis cabinet is supplied as standard with an air-conditioning unit. The air-conditioning unit is attached to the rear door and has a cooling capacity of 1 100 W.

Condensation removal

The Gasmet CEMS analysis system is offered as standard with a plastic tube for removal and disposal of condensation by the customer.

Power supply

The system can be designed either for three phases 115 V AC at 60 Hz, 32 A or 400 V AC, or three phases 230 V AC at 50 Hz, 16 A.

Three phases, neutral and ground must always be provided by the customer.

Analog signal processing

The analog signals are connected as single wires on isolating terminals as standard.

Analyzers

The analysis cabinet is prepared for accommodating one to three analyzers with hot sample feed. As well as the standard Gasmet CEMS FTIR spectrometry unit, the system can also be supplemented with a ZrO₂ oxygen analyzer, as well as a FIDAMAT 6. Different measured components and measuring ranges are available for selection. Other combinations of measured components and measuring ranges are available on request, but you must check that the desired certificates and approvals are available. The analyzers, measured components and measuring ranges used are described briefly below.

Gasmet FTIR spectrometer

For measuring 16 infrared active components as standard. A calibrated measuring range is stored as standard per gas component. Further calibrated measuring ranges per gas component are available upon request for an additional charge.

4

Component		Smallest measuring range	Typical measuring range	Maximum measuring range	Unit
Water	H ₂ O	0 ... 25	0 ... 25	0 ... 30 (On request: 0 ... 40*)	Vol. %
Carbon dioxide	CO ₂	0 ... 10	0 ... 20	0 ... 30	Vol. %
Carbon monoxide	CO	0 ... 70	0 ... 500	0 ... 10 000	ppm
Nitrous oxide	N ₂ O	0 ... 50	0 ... 100	0 ... 500	ppm
Nitrogen monoxide	NO	0 ... 100**	0 ... 200	0 ... 2 000	ppm
Nitrogen dioxide	NO ₂	0 ... 100	0 ... 200	0 ... 500	ppm
Sulfur dioxide	SO ₂	0 ... 30**	0 ... 100	0 ... 2 000	ppm
Ammonia	NH ₃	0 ... 20**	0 ... 50	0 ... 500	ppm
Hydrogen chloride	HCl	0 ... 10**	0 ... 50	0 ... 500	ppm
Hydrogen fluoride	HF	0 ... 17**	0 ... 50	0 ... 100	ppm
Methane	CH ₄	0 ... 50	0 ... 100	0 ... 1 000	ppm
Ethane	C ₂ H ₆	***		0 ... 100	ppm
Ethylene (ethene)	C ₂ H ₄	***		0 ... 100	ppm
n-propane	C ₃ H ₈	***		0 ... 100	ppm
n-hexane	C ₆ H ₁₄	***		0 ... 100	ppm
Formaldehyde	HCOH	***		0 ... 50	ppm
Total carbon (via FTIR measurement)	C _{total} , or THC, TOC	0 ... 15	0 ... 40	0 ... 40	mgC/m ³
Nitrogen oxide (via FTIR measurement)	NO _x	Calculated from N ₂ O, NO and NO ₂			

* Special version without fitness test, as per EN 14181, for an additional charge.

** Smallest measuring range only possible at maximum 30 vol.% water concentration

*** Dependent on the application

Standard components and measuring ranges Gasmet CEMS

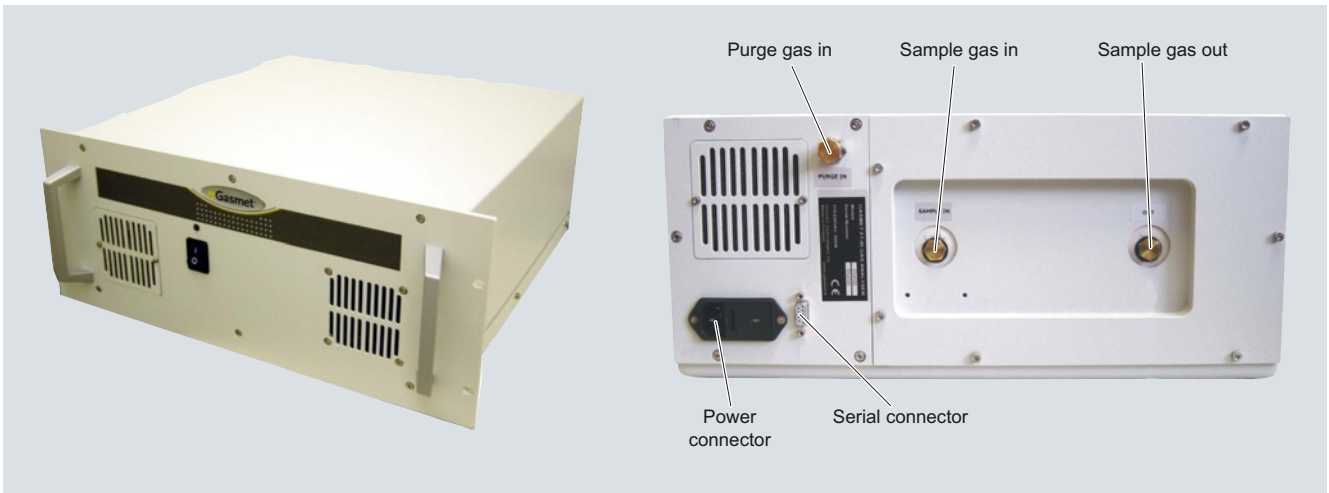

Gasmet CEMS FTIR slide-in unit, front and rear

ZrO₂ oxygen analyzer

Component		Typical measuring range	Unit
Oxygen	O ₂	0 ... 25	Vol. %

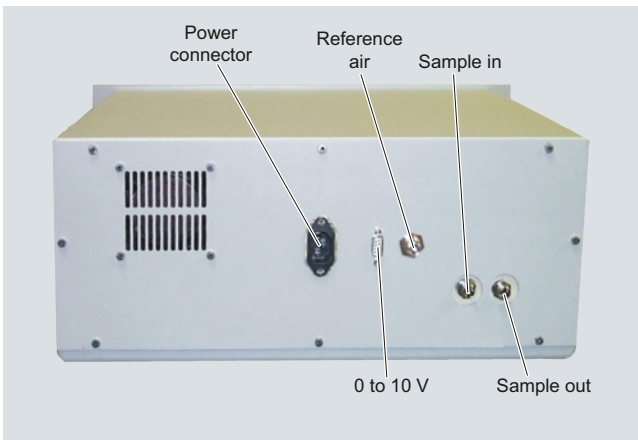

Electrical and gas connections of the ZrO₂ analyzer

FIDAMAT 6

The FIDAMAT 6 is used for FID-based measurement of the total carbon content (C_{total}, THC, TOC value).

Component		Typical measuring range	Unit
Total carbon	C _{total} , or THC, TOC	0 ... 40	mgC/m ³

You can find details of the optional FIDAMAT 6 analyzer in the "Continuous gas analyzers, extractive" chapter of this catalog.

Component		Suitability-tested measuring range *	Additional suitability-tested measuring range *
Carbon monoxide	CO	0 ... 75 mg/m ³	0 ... 300 mg/m ³
Sulfur dioxide	SO ₂	0 ... 75 mg/m ³	0 ... 500 mg/m ³
Hydrogen chloride	HCl	0 ... 15 mg/m ³	0 ... 90 mg/m ³
Nitrogen monoxide	NO	0 ... 200 mg/m ³	0 ... 600 mg/m ³
Nitrogen dioxide	NO ₂	0 ... 200 mg/m ³	
Nitrous oxide	N ₂ O	0 ... 100 mg/m ³	
Ammonia	NH ₃	0 ... 15 mg/m ³	
Carbon dioxide	CO ₂	0 ... 25 vol. %	
Water	H ₂ O	0 ... 30 vol. %	
Oxygen	O ₂	0 ... 25 vol. % ¹⁾	
Total carbon	C _{total} , or THC, TOC	0 ... 15 mgC/m ³ ²⁾	

* A calibrated measuring range is stored in the software of a Gasmet CEMS per measured component as standard. Additional suitability-tested measuring range available, either alternatively or for an additional charge.

1) Using an optionally available, performance-tested ZrO₂ oxygen analyzer

2) Using an optionally available, performance-tested FID analyzer

Performance-tested measuring ranges of the Gasmet CEMS analysis system, in accordance with EN14181

Other combinations of measured components and measuring ranges are available on request, as well as other sample gas components. In this case, you must check that the desired certificates and approvals are available.

Analytical Application Sets

Gasmet CEMS

Control and analysis unit



An industrial PC with Windows operating system and RAID hard drives is used in the Gasmet CEMS analysis system for controlling the sampling unit and the analyzers, as well as for data analysis and forwarding of the analysis data to the process control system. The GASMET Calcmet software is used as the control and analysis software.

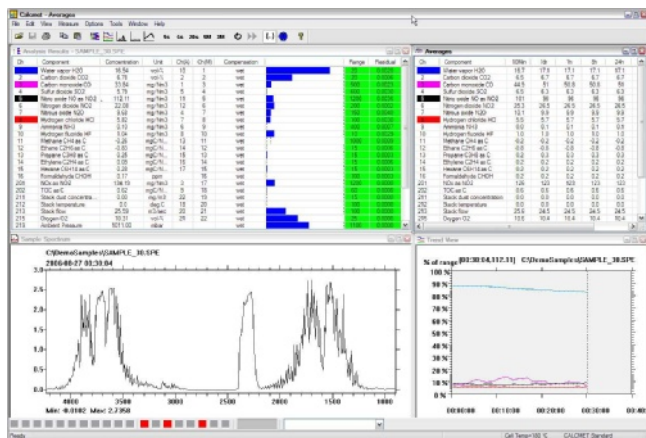

Operator interface of the Calcmet software of the Gasmet CEMS analysis system

The standard configuration enables control and monitoring of the analyzers via the serial interface, watchdog support, as well as remote monitoring and maintenance options for the service and maintenance personnel.

Zero gas and calibration gas supply

The Gasmet CEMS analysis system is equipped as standard with two solenoid valves for the automatic infeed of zero gas and calibration gas.

Either nitrogen (quality: at least 5.0) or purified instrument air is used as the zero gas for the FTIR analyzer, which must be fed in at a pressure of 2 000 hPa.

The span gas must contain one or more of the gas components to be monitored, depending on requirements and/or official regulations. The calibration gas must also be fed in at a pressure of approx. 2 000 hPa.

Instrument air supply

The FTIR interferometer of the Gasmet CEMS is purged continuously with instrument air at an even flow rate of approx. 0.5 l/min.

All internal gas routes of the Gasmet CEMS upstream of the FTIR spectrometer must be kept free of all contamination using clean purge gas before switching on the analyzer with sample gas infeed, or in good time before switching off temperature stabilization of the sample gas lines and the analyzer. This prevents condensation of sample gas components, airborne pollutants, and atmospheric humidity, and/or the accumulation of particles inside the FTIR spectrometer. This prevents irreversible damage to the internal gas cuvette.

Either nitrogen (quality: at least 5.0) or completely oil-free and particle-free instrument air is used as the purge gas.

To enable a "safety purge" of the internal gas routes in particular, the instrument air must always be available at a pressure of approx. 6 bar.

Options/expansions (on request)

- Second/further calibrated measuring range(s) per sample gas component
- Expansion set with solenoid valves for automatic span gas infeed of up to four further span gases
- Instrument air/combustion air processing
- Calibration unit for the recommended annual test with wet gases to adjust the H₂O, NH₃, HCl and HF calibration (can be made available on loan within the scope of a service contract)

Function

Sample gas (max. 600 °C) is continuously taken via a heated sample gas probe, and transported via a heated sample line to the sample pump of the heated sampling unit in the air-conditioned analysis cabinet. Heating to 180 °C prevents condensation in the analysis system. From the sampling unit, the sample gas flows via further heated sample gas lines continuously through the gas cuvette of the actual FTIR analyzer, as well as, through the gas cuvette of the optional ZrO₂ oxygen analyzer.

In the FTIR analyzer, spectra of the gas mix in the infrared spectrum range are recorded at intervals of a few seconds. The generated interferograms are added together and converted to infrared spectra using mathematical Fourier transform routines. The result is the absorption spectrum of the sample gas, averaged over 60 seconds. The concentrations of the individual components are calculated using multivariate-multicomponent analysis.

A connected industrial PC, equipped with the special Calcmet software, handles control of the measurements, analysis of the measured spectra, control of other programmable sequences, and output of the analog and status signals.

FTIR spectroscopy is outstandingly suitable for multicomponent analysis of numerous gas components. However, the oxygen concentration important for emission measurements, and the concentrations of other non-infrared-active gases such as inert gases or hydrogen, cannot be determined in this way.

For measuring O₂, the system can be optionally equipped with a ZrO₂ oxygen analyzer that can be integrated into the Gasmet CEMS as a further 19" rack unit, and controlled using the Calcmet software.

The FTIR method offers the possibility of calculating a "total organic carbon value" from the individual concentrations of several hydrocarbons stored in the Gasmet CEMS standard calibration library. If direct total organic carbon measurement using the FID method is required, a further free 19" slot of the Gasmet CEMS can be optionally equipped with a FIDAMAT 6.

The cabinet of the Gasmet CEMS analysis system is equipped as standard with an air-conditioning unit mounted on the rear. Power supply versions are available for 115 V AC or 400 V AC.

Gas flow charts and electrical connections

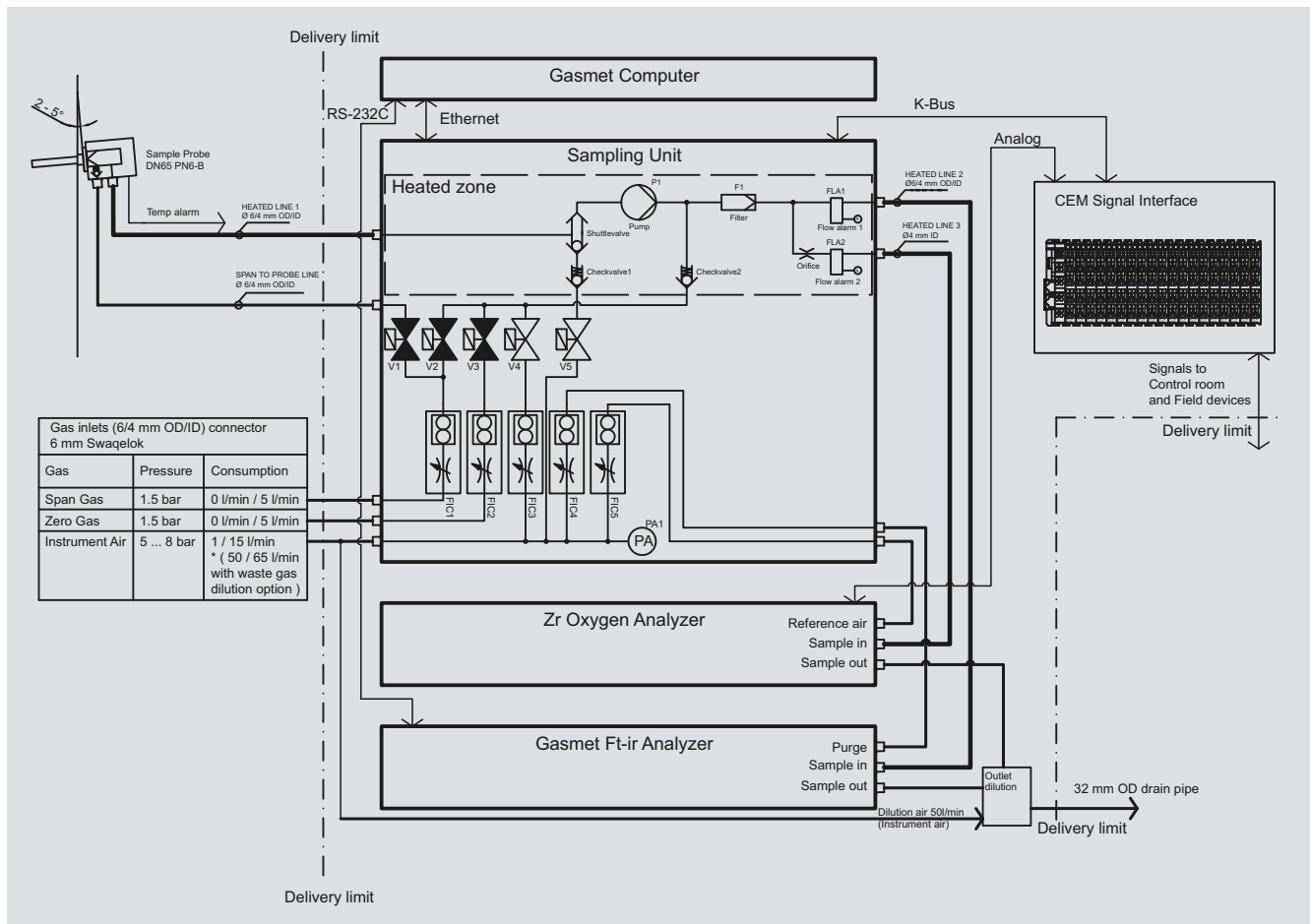

Gasmet CEMS: Gas flow chart including options

Analytical Application Sets

Gasmet CEMS

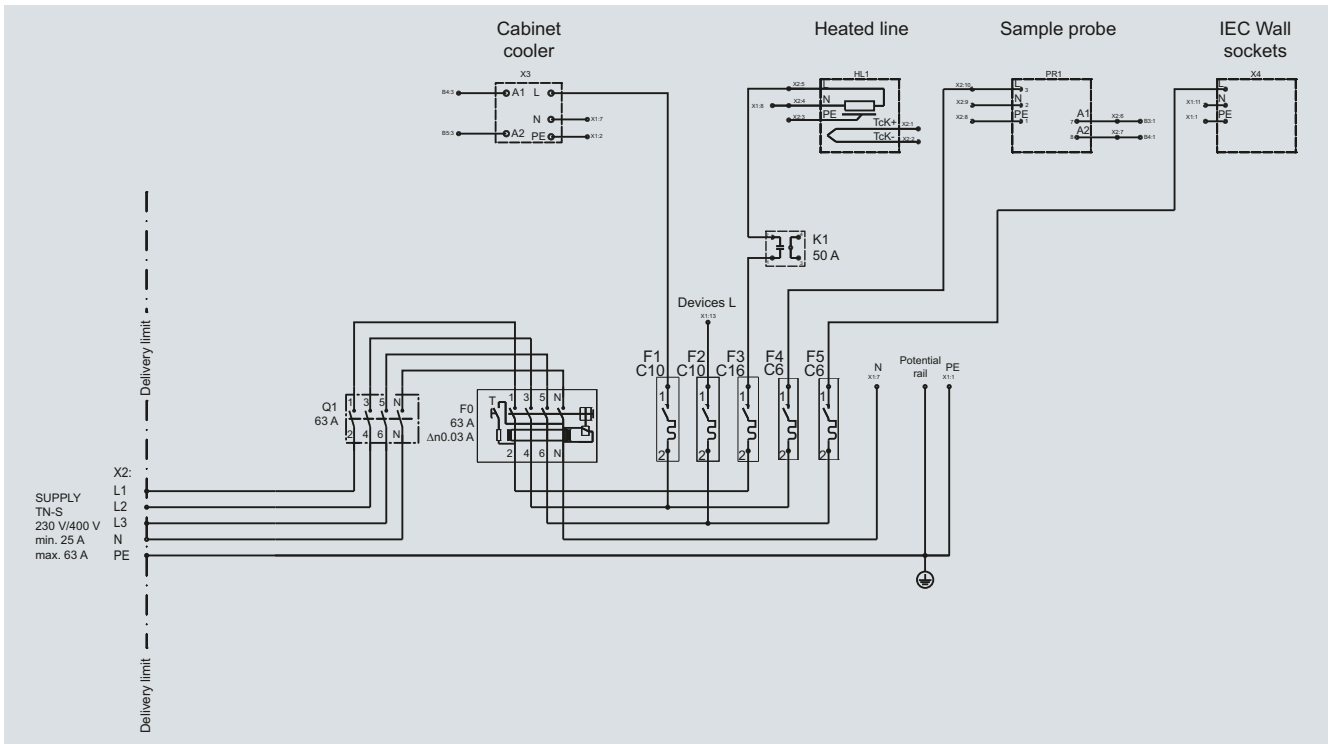

Gasmet CEMS: Electrical connections, including options

Technical specifications

General data

Measuring principle	<ul style="list-style-type: none"> Fourier transform infrared (FTIR) spectroscopy for oxygen: ZrO₂ measuring cell (optional) for total carbon (C_{total}, THC, TOC) <ul style="list-style-type: none"> FTIR, not performance-tested (standard) FID analyzer, also performance-tested in accordance with EN 14181 if required (option)
Performance capability	Simultaneous analysis of up to 50 gas components Standard: 16 components
T90 time	< 180 s, with 20 m sample gas line
Climatic conditions	
<ul style="list-style-type: none"> Ambient temperature during operation Ambient conditions during storage and transportation Site 	0 ... 40 °C, non-condensing -20 ... 60 °C, 0 ... 95 % relative humidity, no condensation Indoors, dust-free, clean ambient air, no external vibrations
Ex zone	Non-Ex area (IEC General Purpose)
System design	
<ul style="list-style-type: none"> Type Cabinet degree of protection 	Cabinet configuration IP54
Electrical connections	
<ul style="list-style-type: none"> Supply voltage (alternative 1) Supply voltage (alternative 2) Power consumption 	3 phases 115 V AC (-15 %, +10 %) / 60 Hz, 32 A + neutral + ground (TN-S) 400 V AC (-15 %, +10 %) / 50 Hz, 3 phases 230 V AC (-15 %, +10 %) / 50 Hz, 16 A + neutral + ground (TN-S) Gasmet CEMS with 20 m heated sample gas line: approx. 7.5 kW
Dimensions (with plinth)	2 100 x 600 x 800 (+ 250) mm (H x W x D)
Weight	Gasmet CEMS with FTIR and O ₂ analyzers: Approx. 320 kg *)

Electrical inputs/outputs

<ul style="list-style-type: none"> Analog outputs Analog inputs 	16 channels, 4 ... 20 mA, isolated, freely programmable 8 channels, 4 ... 20 mA, isolated, freely programmable
<ul style="list-style-type: none"> Digital outputs Digital inputs 	16 channels, 24 V DC, freely programmable System alarm, maintenance requirement, maintenance, measured value overshoot, valid measured value 16 channels, floating contacts Temperature alarm sampling probe, temperature alarm analysis cabinet, alarm air-conditioning unit on the analysis cabinet, alarm zero gas pressure, alarm O ₂ analyzer, activated scan gas infeed via sampling probe, activated system standby
Optional expansions	Up to 255 terminal strips
Interfaces (optional)	RS 232, RS 422/485, Modbus, PROFIBUS

Sampling unit

Temperature controller for heated sample gas lines	0 ... 180 °C
Type of temperature sensor in sample gas lines	K type (Ni-Cr-Ni element)
Gas inlet conditions	
<ul style="list-style-type: none"> Max. sample gas pressure at inlet to sample preparation system Sample gas temperature at inlet to sample preparation system Dust content at inlet to sample preparation system Instrument air Flow rates 	1 500 hPa 180 ... 200 °C, non-condensing Dust-free Oil-free and dust-free instrument air, dew point < -40 °C <ul style="list-style-type: none"> Sample gas: Approx. 0.4 l/min Zero gas: Approx. 0.5 l/min Calibration gas: Approx. 0.5 l/min Instrument air for purging the FTIR spectrometer: <ul style="list-style-type: none"> Normal mode: Approx. 0.5 l/min Safety purging: Approx. 4 l/min Reference air for optional O₂ measurement: Approx. 0.7 l/min
<ul style="list-style-type: none"> Gas inlets Gas outlets Gas connections 	Sample gas (heated to 180 °C), span gas, zero gas, instrument air FTIR analyzer (heated), O ₂ analyzer (heated), span gas for sample probe, interferometer purging, reference air for O ₂ analyzer Swagelok 6 mm, for sample gas lines with 4/6 mm internal/external diameters
Sample gas pump	
<ul style="list-style-type: none"> Material Membrane Maximum flow rate Heated filter 	Stainless steel 316 PTFE 4 l/min For particles > 2 µm
Valves	
<ul style="list-style-type: none"> Solenoid valves Shut-off valves 	Sample gas / backflushing, span gas via sample outlet, span gas via sample probe, zero gas, instrument air (safety circuit) Sample gas/backflushing, gas infeed for maintenance purposes

FTIR spectrometer unit

Measuring principle	Fourier transform infrared (FTIR) spectroscopy
Spectral resolution	Standard: 8 cm ⁻¹
Scan rate	10 scans / s
Detector	Peltier cooled MCT
Infrared light source	SiC, 1 550 K
Beam splitter and window material	ZnSe
Spectral range	4 200 ... 900 cm ⁻¹ (2.4 ... 11 µm)
FTIR gas cuvette	Multiple path gas cell with fixed optical path length: 5.0 m
<ul style="list-style-type: none"> Material Mirror Cuvette volume 	Standard: 100 % rhodium-coated aluminum Gold coating 0.4 liters

Analytical Application Sets

Gasmet CEMS

• Gaskets	Standard: Viton O rings, others: On request
Window material	BaF ₂
Interferometer purging	<ul style="list-style-type: none"> • Oil-free and particle-free instrument air, dew point < -40 °C, 0.5 l/min • Nitrogen (at least 5.0)
Measuring performance	
• Zero point checking:	Recommendation: Automatic "zero point calibration" with nitrogen every 24 hours (Quality of the nitrogen: 5.0 or higher)
• Zero point drift:	< 2 % of the measuring range of the "zero point calibration"
• Linearity error	< 2 % of the measuring range
• Temperature impact	< 2 % of the measuring range per 10 K temperature change
• Pressure influence	1 % of the measured value at 1 % sample gas pressure change. Ambient pressure fluctuations are measured and compensated for

Oxygen analyzer (optional)

Measuring principle	ZrO ₂ measuring cell
Detection limit	< 1 ppm O ₂
Reference gas	<ul style="list-style-type: none"> • Oil-free and particle-free instrument air, dew point < -40 °C • Calibration gas
Sensor material	Stainless steel 316 (1.4571)
Gas flow	Minimum 0.1 l/min
Measuring ranges	Min. 0 ... 2 vol.% O ₂ Type 0 ... 25 vol.% O ₂
Accuracy	± 0.2 % of the measuring range

FIDAMAT 6 (optional) See "Continuous gas analysis, extractive"

Measuring principle FID analyzer

*) The system is supplied partially disassembled in several packages: Analyzer rack units, sampling unit, industrial PC, air conditioning unit and preconfigured analysis cabinet.

Selection and ordering data	Order No.
Gasmet CEMS FTIR analysis system for continuous emissions monitoring Incl. GASMET FTIR analyzer, Gasmet CEMS sampling unit, industrial PC, TFT screen, keyboard Standard analog and digital inputs/outputs	7MB1956 -
Cabinet configuration Cabinet configuration 1 with plinth, 2 100 x 600 x 800 + 250 mm (H x W x D), air-conditioning unit on rear Cabinet configuration 1 on rollers, 2 100 x 600 x 800 + 250 mm (H x W x D), air-conditioning unit on rear	0 1
Sample gas probe Without sample gas probe	A
Heated sample gas line Without heated sample gas line	A
FTIR measurement Standard CEMS FTIR unit 1	0
Oxygen measurement No O ₂ measurement Prepared for accommodating a suitable ZrO ₂ O ₂ analyzer (19" rack unit) Including ZrO ₂ analyzer	0 1 2
Total carbon measurement FTIR-based total carbon measurement (not performance-tested) Prepared for accommodating an additional total carbon (FID) analyzer (19" rack unit)	1 2
Software version Calcmet software version 11.1x	A
Fieldbus version Modbus via RS 232	A
Power supply 400 V AC / 50 Hz, on customer side: 3 phases (230 V / 16 A), neutral, ground 115 V AC / 60 Hz, on customer side: 3 phases (115 V / 32 A), neutral, ground	0 1
Additional versions	
Please add "-Z" to Order No. and specify order code.	
Calibration certificate (certificate of the gas cylinder with which the calibration has been made)	A01
Accessories Portable GASMET calibration gas generator for H ₂ O and liquid calibrations; including heated probe line as well as 5 ml and 1 ml injectors Rollers for housing cabinet, supplied separately	KHZ-GM-CAL-301 KHZ-GM-CAB-OPT-120

Analytical Application Sets

Gaset CEMS

Recommended spare parts schedule

Description	Annually	Every 2 years	Every 3 years	Item no.
Filter set for housing fan (10 units)	X			KHZ-GM-COW-FIL-003
Special tool for changing the diaphragm of the sample gas pump	X			KHZ-GM-GAS-TOOL-001
O-ring filter element	X			KHZ-GM-SAM-FIL-004
Heated filter element 0.1 µm, stainless steel	X			KHZ-GM-SAM-FIL-009
Set of diaphragms for sample gas pump	X			KHZ-GM-SAM-FLOW-100
IR light source unit		X		KHZ-GM-OPE-IRS-620
Laser unit			X	KHZ-GM-OPE-LAS-630
Temperature fuse 229 °C, with crimp connections			X	KHZ-GM-SMP-HEAT-002
Set of Viton gaskets (standard) for gas cuvette	X ¹⁾			KHZ-GM-SMP-GASK-738
Set of Viton gaskets, coated with Teflon, for gas cuvette	X ¹⁾			KHZ-GM-SMP-GASK-739
Set of Kalrez gaskets (type 7075) for gas cuvette	X ¹⁾			KHZ-GM-SMP-GASK-740

¹⁾ Dependent on the configuration of the FTIR spectrometer: Please specify the serial number of the FTIR spectrometer unit if ordered separately

Dimensional drawings

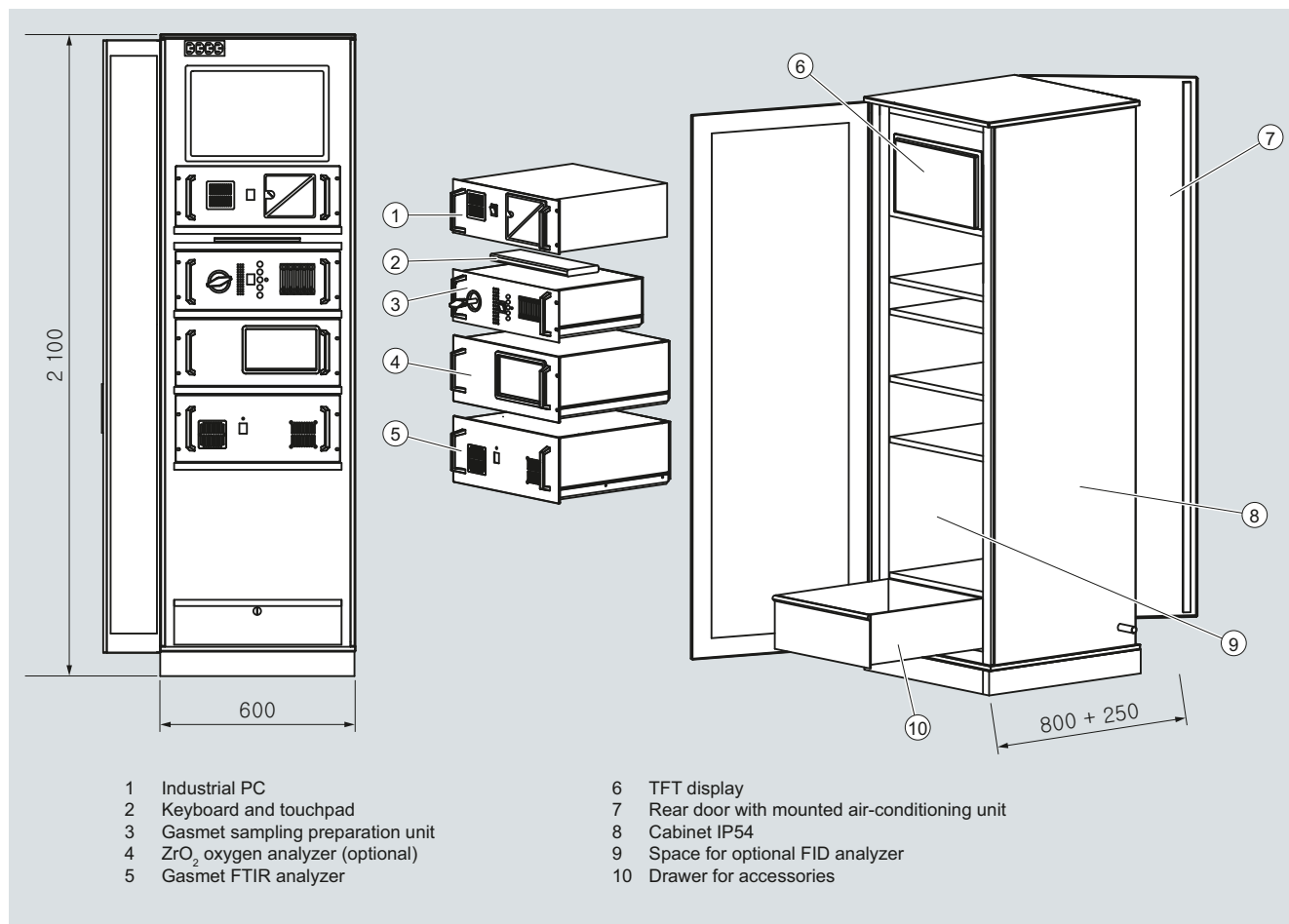

Design of the Gaset CEMS analysis system

More information

Preventive maintenance

The table below offers a general overview of the recommended tasks for preventive maintenance for a Gasmet CEMS analysis system. The actual requirements depend heavily on the

individual conditions of the application and installation. The tasks that can be carried out by the operating personnel are described in detail in the documentation supplied with each system. For more comprehensive work, special training courses or service contracts are offered.

Maintenance interval	Task(s)	To be carried out by
Daily	Zero gas infeed	Automated
1 week	Visual inspection of the system and the included analyzers	Operating personnel
1 week	Visual inspection of the sampling unit	Operating personnel
Approx. 30 days	Zero gas and span gas infeed	Automated
2 to 6 months	Inspection and replacement of the filters of the sample probe and the sampling unit	Specially trained operating personnel (included in the annual service with the service contract)
Approx. 3 months	Inspection of the oxygen calibration of the ZrO ₂ oxygen analyzer	Automated (included in the annual service with the service contract)
Approx. 12 months	Inspection of the gas cell of the FTIR analyzer	Trained service engineer (included in the annual service with the service contract)
Approx. 12 months	If required: Replacement of the diaphragm of the sample pump	Trained service engineer
Approx. 12 months	Infeed of wet span gases (for NH ₃ , HCl, HF measurement), adjustment of the "water calibration"	Specially trained service engineer (included in the annual service with the service contract, including provision of the calibration unit required for this purpose)
18 to 60 months	If required: Replacement of optoelectronic components (e.g. laser and infrared light source) of the FTIR analyzer	Trained service engineer

Suggestion for preventive maintenance of a Gasmet CEMS analysis system

Automated maintenance

Zero gas infeed

The Gasmet CEMS carries out automatic "zero gas calibration" daily at definable times. With the help of controllable solenoid valves, the FTIR gas cuvette is flushed for several minutes with "zero gas", usually nitrogen, instead of sample gas.

Zero gas and span gas infeed

An infeed of span gas using dry span gases is recommended at regular intervals, such as every 30 days, before infeed of the zero gas. Span gas infeed can also be automated via controllable solenoid valves.

Annual inspection of wet span gases

Recording of a new water spectrum using the FTIR unit of the Gasmet CEMS analysis system is recommended once a year.

Wet span gases for adjusting the system should also be supplied once a year for the gas components ammonia, hydrogen chloride and hydrogen fluoride.

These tasks must be carried out by a specially trained service engineer, e.g. within the scope of a service contract.

Span gases and nitrogen are required for these inspections as well as a special calibration unit. That accessory can be provided on loan within the scope of a service contract.



The Gasmet CEMS calibration unit for water

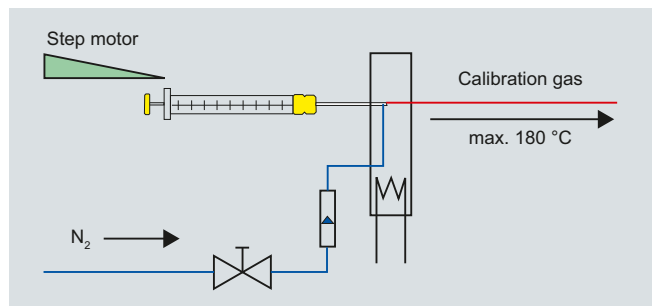

Functional principle of the Gasmet CEMS calibration unit for water

Overview

The ASM is a PC-based HMI system for monitoring, testing and administration of analyzers in subsystems or in the complete plant. The relevant information of the analyzers is collected over a uniform communications network and saved in a central database. By means of the PC's user-friendly operator interface it is possible to access measured-value trends, device statuses and statistical evaluations, among others, or to start test routines for validation of the results. A comprehensive reporting module is available to document the evaluations.

Benefits

- Monitoring, testing and administration of many different types of analyzers using one system
- Visualization and operation using a single-user system up to distributed multiuser systems with redundant servers
- Assessment of the measured-value reliability through checking of the analyzers using various validation routines, e.g. based on the industry standard ASTM D 3764
- Increase in analyzer online time through use of the line sample method
- Statistical evaluation of operating statuses and determination of key performance indicators (KPI) such as availability, error rate and maintenance frequency
- Reduction in maintenance costs through device-specific planning, implementation and checking of maintenance work
- Documentation of the performance of individual analyzers up to the complete plant using the reporting module. The reports can be saved in the ASM or exported for further use.

Application

The ASM is ideal for all systems and plants where high reliability of the measured values and documentation of the analyzer performances are required. Using the communications network, remote analyzers can also be monitored from a central workstation.

The ASM is particularly suitable for use in the oil & gas, petrochemical, and chemical industries, and can be applied in new plants or also in existing plants to optimize the analyzer landscape.

Design

System design

- PC-based HMI system
- Visualization and operation possible using a single-user system up to distributed multi-user systems with redundant servers
- Logging and archiving of process and system data in a central database
- Integration of different analyzers in a uniform communications network

System software

- Siemens SIMATIC WinCC for the HMI functions
- Microsoft SQL Server for archiving and data collection
- Microsoft Windows/ Windows Server as operating system

Communication

- An Ethernet network is the basis for communication
- Integration of analyzers using PROFINET, ModbusTCP or OPC data exchange
- Analyzes without a communication interface can be integrated by connecting the signals to Siemens SIMATIC components
- Data exchange with other systems possible using OPC

Networking

- Siemens Scalance Ethernet switches for design of electrical and optical Industrial Ethernet in line and star structures; design in ring structures is possible to increase the fail-safety of the network
- Integration of the ASM in an existing Ethernet network may be possible

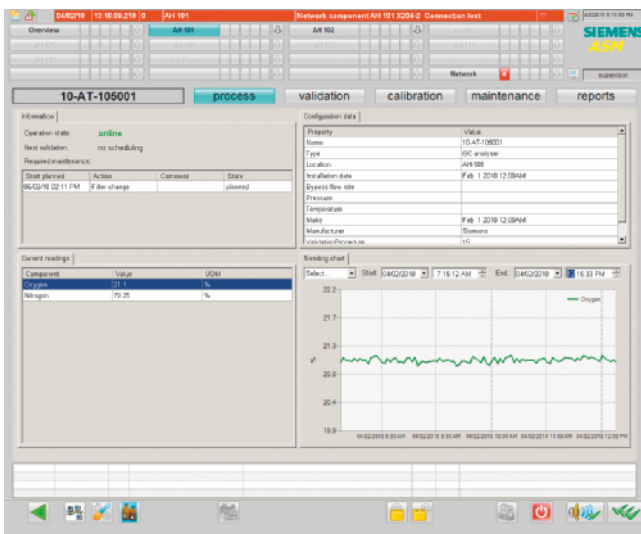

View of the process module

Function

General information

The information of the analyzers is collected over the communications network and saved in the central ASM database for further analysis. The ASM is accessed using a Windows workstation, and it is possible to navigate between overview displays, device-specific displays, and general functions.

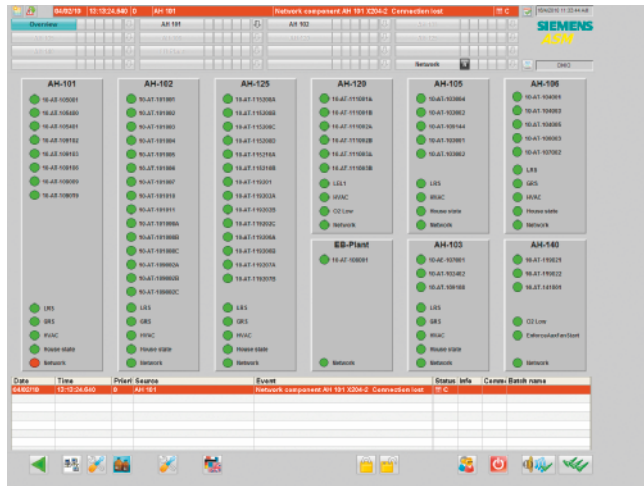

Overview of analyzers in a plant

The ASM has the following function modules for each analyzer for carrying out the HMI tasks:

Module	Task
Process	Provides a detailed overview of the selected analyzer. The current analyzer status, planned maintenance work, and configuration data are displayed. The current measured values are displayed in a table, historical values can be analyzed with the trend display using selectable time windows.
Validation	Checking the reliability of the measured values of analyzers using various routines and methods. This test can be started automatically at specific intervals or manually by the ASM.
Calibration	Carries out a calibration on the analyzer and monitors the results (this module is only available for analyzers which support remote calibration, e.g. Siemens Maxum Ed. II, Siemens MicroSAM, ...).
Maintenance	Device-specific maintenance tasks can be specified here, their timing defined, and checked. Documentation such as maintenance procedures or manuals can be opened to support the maintenance work. The view of key performance indicators (KPI) provides a fast overview of the analyzer's performance such as availability, error rate and maintenance frequency
Reporting	This is a comprehensive function for producing customized reports. The module permits analysis of current and historical data in selectable time periods for documentation of the performance of individual analyzers up to the complete plant using the reporting module. The reports can be saved in the ASM or exported for further use.

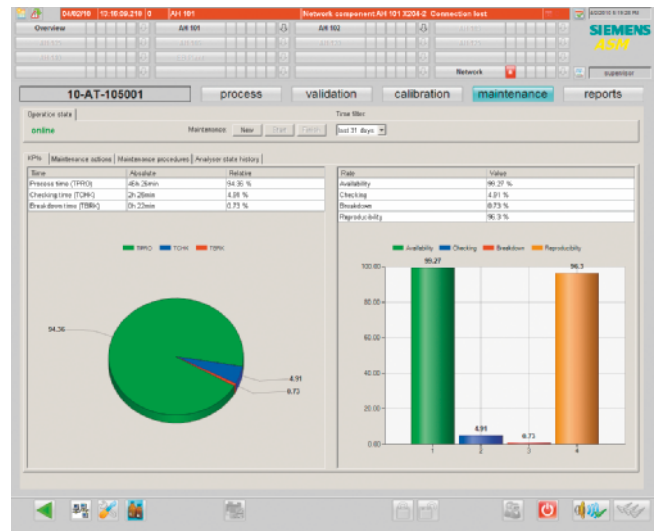

View of the maintenance module

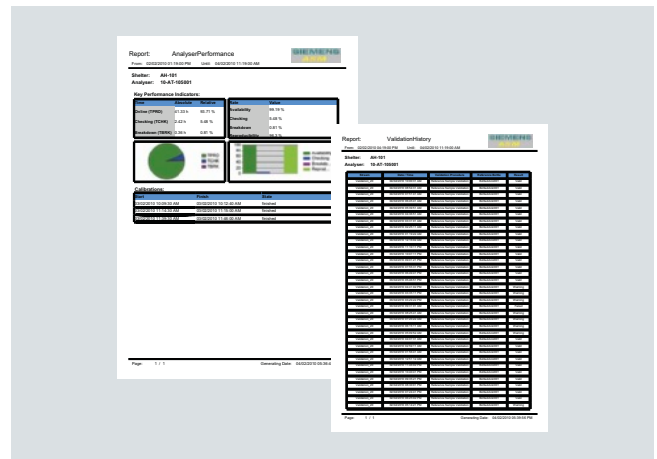

Examples of generated reports

Analytical Application Sets

Set ASM

Further functions are:

Function	Task
SCADA	The ASM provides all typical SCADA functions such as: <ul style="list-style-type: none"> • Password protection and different access privileges • User administration • Signaling, acknowledgment and archiving of alarms and events
Network screen	Status display of the network devices. This overview displays the statuses of the Ethernet switches (online/uncertain/fault). The analyzer alarms are integrated in the ASM signaling system.
Reference bottle management	Management and assignment of reference gas cylinders. This information serves as reference values for the validation using the reference sampling method.
Equipment engineering	For configuring the analyzers. Among others, the analyzer-specific data is entered here, the type of validation is defined, and the number of measured values and units is entered.
Maxum software	Direct calling of the comprehensive Siemens configuration and operation software for Siemens Maxum edition II and MicroSAM. It is then possible to access the connected analyzers for maintenance, configuration, or viewing of chromatograms.

4

Validation

One of the core functions of the ASM is checking the analyzers for reliability of the measured values. Two different methods of measurement are available for recording the values, namely the reference sample method and the line sample method. The resulting values can be checked using different evaluation methods (based on ASTM D3764 or deviation). The objective of the validation is to recognize fluctuations and deviations with respect to a comparison value, and to thus permit a statement to be made on the reliability and drift of the measurement.

Method of measurement: reference sample method

The analyzer is disconnected from the process gas, and a reference gas connected for measurement. The composition of this reference gas has previously been specified in the "Reference bottle management" of the ASM. Using these values, the ASM determines the deviation between the measurement and the reference data.

Method of measurement: line sample method

With this method, a gas sample is extracted from the stream of sample gas to the analyzer, and analyzed in the laboratory. The resulting values are passed on to the ASM and compared with the analyzer's measured values. With this method, the analyzer need not be disconnected from the process gas, and permanently remains available for the process measurement.

Evaluation based on ASTM D3764

Based on the international standard ASTM D3764, the results are checked using various statistical methods, including standard deviation, Dixon freak value test, and systematic error.

Evaluation using deviation method

Limit values are defined for this evaluation: the warning limit and the control limit. Simple rules are used to define how the reliability of the measurement is to be assessed when these limits are violated. For example, it can be defined that a single violation of the limit can be tolerated, but that repeated violation is an impermissible condition.

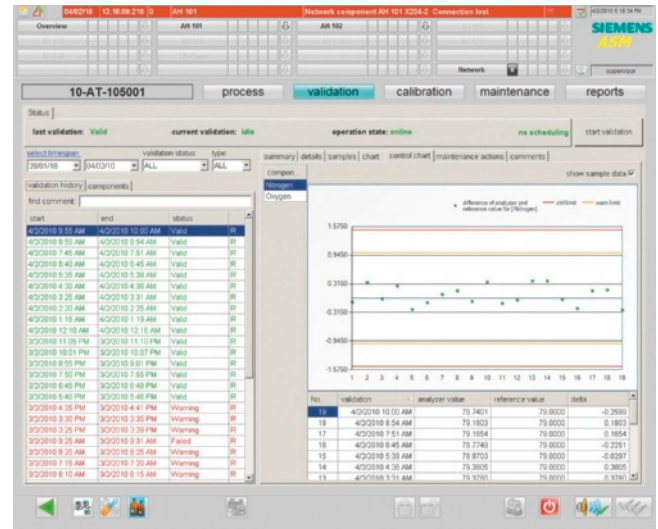

View of the validation module

Technical specifications

PC hardware requirements

- Processor type (recommended)
 - Server: dual core, 3 GHz
 - Client: Client: dual core, 2 GHz
- RAM (recommended)
 - Server: 4 GB
 - Client: 2 GB (1)
- Graphics card (recommended)
 - 32 MB, 1280 x 1024¹⁾
- Hard disk (recommended)
 - Server: 2 x 160 GB (Raid 1)
 - Client: 80 GB
- Hard disk (free space for installation, recommended)
 - Server: > 40 GB
 - Client: > 1.5 GB
- DVD-ROM/ USB port
 - For software installation

¹⁾ Hardware requirement when using Microsoft XP Professional

Selection and ordering data

Please contact your Siemens sales partner for further information and for ordering.

Overview



The Set BGA (**biogas analyzer**) is a standardized system for stationary, continuous operation for the analysis of landfill gas, sewage gas or biogas.

Benefits

Standardized complete system

The standardized complete system has a modular configuration and can thus be used at various measuring locations for different measuring tasks.

- Simple and fast to configure
- Field-tested and matched Set in rugged industrial design
- Extremely high long-term stability
- The Set BGA is based on the proven ULTRAMAT 23

Field-proven, reliable technologies

- Autocalibration function with ambient air reduces the maintenance requirements
- Detonation protection in accordance with EN 12874
- Modular system design based on long-term tested components
- LEL sensor for cabinet monitoring (optional)

Simple operation

- Intuitive menu guidance
- Configuration on large displays with plain text
- Two freely-configurable limits per measured component

Application

The efficiency of biogenic production processes and optimum operation of the plant largely depends on continuous monitoring of the biogas composition. The basic version of the Set BGA analyzes CH_4 and CO_2 using the proven ULTRAMAT 23 IR analyzer. The concentrations of O_2 and H_2S are optionally measured using electrochemical sensors and also converted into output signals of 4 to 20 mA. In this manner, the Set BGA contributes to operational safety and explosion protection in addition to process optimization.

The modular design of the system takes into account the physical conditions of the gas with regard to temperature and moisture in that various gas preparation components for heating or drying the sample gas can be configured as required.

The gas mixture can be explosive at critical concentration ratios between methane and oxygen. Even if such critical gas compositions occur extremely rarely, the danger of ignition must nevertheless be avoided. For this reason, the Set BGA is designed with a high safety standard and even the basic version is equipped with flow monitoring and detonation protection in accordance with EN 12874 in the sample gas path. To increase safety even further, a gas sensor for monitoring the ambient air can be connected as an option.

It is also possible to monitoring up to four measuring points using an optional sample switching cabinet. In this case the sample flows are sucked in continuously using a powerful pump in order to achieve fast measuring times.

Analytical Application Sets

Set BGA

Design

The Set BGA consists of the following components:

- ULTRAMAT 23 analyzer with four measured components max.
- Analyzer cabinet with modularly configurable gas preparation components
- Cabinet for measuring point switchover (option)
- Heated line (option)

The ULTRAMAT 23 is selectable with two IR components (CO₂ and CH₄). Furthermore, the configuration can be equipped with an electrochemical oxygen sensor and/or an electrochemical hydrogen sulfide sensor. The corresponding measuring ranges are listed in the table below.

Measured component	Smallest measuring range	Largest measuring range
CO ₂	0 ... 20 %	0 ... 100 %
CH ₄	0 ... 20 %	0 ... 100 %
O ₂	0 ... 5 %	0 ... 25 %
H ₂ S (high)	0 ... 500 ppm	0 ... 5 000 ppm
H ₂ S (low)	0 ... 5 ppm	0 ... 50 ppm

The ULTRAMAT 23 calibrates the IR components and the electromechanical oxygen sensor automatically with ambient air. Calibration with calibration gas is recommended once a year or after oxygen sensor replacement. In order to comply with the technical specification data, the hydrogen sulfide sensor must be calibrated every three months. An appropriate calibration gas is therefore required. It is supplied to the analyzer through a manually switchable ball valve.



Set BGA measuring system



2-stream sample preparation

Technical specifications

Installation

Ambient temperature	5 ... 38 °C, with cabinet heating ± 0 °C
Site	Indoor/outdoor installation (configurable)

Gas inlet conditions

Sample gas pressure	<ul style="list-style-type: none"> • Without pump, not pressurized (< 1 200 mbar absolute); pressure reduction must be provided for higher input pressures • With pump, depressurized suction mode
Pump performance	Adjustable to 60 ... 80 NI/h
Sample gas temperature	Max. 45 °C, with moisture saturation

Power supply

Supply 1	200 ... 240 V AC, 47 ... 63 Hz
Supply 2	100 ... 120 V AC, 47 ... 63 Hz
Power consumption	Approx. 180 VA (without cooler and sample preparation)

Connection systems

Teflon hose	With PVDF screwed glands
Connection systems	Metric (6 mm) or imperial (1/4") selectable

Dimensions

Set BGA measuring system (W x H x D)	600 x 781 x 600 mm
Sample preparation (W x H x D)	600 x 600 x 220 mm

Weight

Set BGA measuring system	Approx. 50 kg
Sample preparation	Approx. 22 kg

System design

System enclosure	3-part sheet-steel enclosure with window
Degree of protection	IP54
Cabinet conditioning	Fan
Cooling system	Peltier cyclone cooler (optional)
Sample preparation	Max. four sample streams can be controlled using Logo module with fast loop pump in separate enclosure
Analog outputs	Per component 0/2/4 ... 20 mA; NAMUR, floating, max. load 750 Ω

Measured components / measuring ranges

CH ₄	0 ... 100 vol% to 0 ... 20 vol% (NDIR)
CO ₂	0 ... 100 vol% to 0 ... 20 vol% (NDIR)
O ₂	0 ... 25 vol% to 0 ... 5 vol% (electrochemical); optional
H ₂ S	0 ... 5 000 vpm to 0 ... 500 vpm (electrochemical); optional

Safety assemblies

Assembly 1	Detonation protection F501
Assembly 2	Flow measurement with limit monitoring at the output
Assembly 3	LEL monitoring (optional)

Comment

- The system concept of the Set BGA is based on the preconfigured ULTRAMAT 23 solutions (7MB2335-..., 7MB2337-...)
- The technical performance data concerning the measuring response correspond to the catalog data of the ULTRAMAT 23. The pre-configured version does not contain any ULTRAMAT 23 add-ons or retrofitting sets.

Selection and ordering data	Order No.
<p>Set BGA basic configuration, including flame arrestor</p> <p><u>Gas connections, external</u> 6 mm ¼ inch</p> <p><u>Sample conditioning</u> Without gas cooling Passive cooling (supplied separately) Peltier cooler, integrated in Set BGA enclosure</p> <p><u>Enclosure design</u> Not heated Electrically heated</p> <p><u>Pump design</u> Without pump Internal pump in analyzer External pump, fitted in Set BGA enclosure</p> <p><u>Power supply</u> 120 V AC, 60 Hz 230 V AC, 50 Hz 110 V AC, 50 Hz</p> <p><u>Infrared measured components</u> Measured component CH₄, 0 ... 20 % to 0 ... 100 % Measured component 1 CO₂, 0 ... 20 % to 0 ... 100 % Measured component 2 CH₄, 0 ... 20 % to 0 ... 100 %</p> <p><u>Oxygen measurement</u> Without O₂ sensor With O₂ sensor, 0 ... 5 % to 0 ... 25 %</p> <p><u>H₂S measurement</u> Without H₂S sensor With H₂S sensor, 0 ... 500 ppm to 0 ... 5 000 ppm With H₂S sensor, 0 ... 5 ppm to 0 ... 50 ppm</p> <p><u>Documentation</u> German, 1 set (paper and CD) English, 1 set (paper and CD) French, 1 set (paper and CD)</p>	<p>7MB1955-</p> <p>0 1</p> <p>A B C</p> <p>A B</p> <p>0 1 2</p> <p>0 1 2</p> <p>0 1</p> <p>A B</p> <p>A B D</p> <p>0 1 2</p>
<p>Further versions (add-ons)</p> <p>Add "-Z" to Order No. and specify order code</p> <p><u>Heated sample gas line, self-regulating, Ex-proof</u> Length: 5 m, supplied separately Length: 10 m, supplied separately Length: 15 m, supplied separately Length: 20 m, supplied separately Length: 25 m, supplied separately Length: 30 m, supplied separately Length: 35 m, supplied separately</p> <p><u>Communication</u> PROFIBUS DP interface</p> <p><u>Fast loop design and sample switching</u> 2-stream sample switching with Logo and external pump 3-stream sample switching with Logo and external pump 4-stream sample switching with Logo and external pump 5-stream sample switching with Logo and external pump 6-stream sample switching with Logo and external pump</p> <p><u>Gas sensor for leak monitoring of the Set BGA system</u> Alarm monitoring: 20 % LEL methane</p>	<p>A01 A02 A03 A04 A05 A06 A07</p> <p>A13</p> <p>B02 B03 B04 B05 B06</p> <p>C01</p>

Analytical Application Sets

Notes

4